

# ASSESSMENT OF A TREATMENT SCHEME FOR ACIDIC MINING LAKES USING CO<sub>2</sub> AND CALCIUM OXIDES TO PRECIPITATE CARBONATES<sup>1</sup>

Florian Werner<sup>2</sup>, Bastian Graupner<sup>3</sup>, Broder Merkel<sup>4</sup>, and Christian Wolkersdorfer<sup>5</sup>

**Abstract.** Carbon dioxide and calcium oxides may be used to neutralize acidic lakes. In lignite producing areas combustion power plants producing CO<sub>2</sub> are often close to pit lakes. If fly ashes from these power plants could be used as calcium oxide source, carbonate precipitation in lakes could as also as a mineral trap to dispose of CO<sub>2</sub>. In a preliminary step the feasibility of this treatment scheme is investigated and includes a model based assessment of expected effects on the surface water, the reactivity of the chemical components, and the technical prerequisites. A pit lake in the Lausitz (Lusatia) post mining area in Germany was chosen as a test site, where fly ash has been deposited for more than 25 years. The feasibility of re-suspending these deposits to neutralize the lake was demonstrated in the years 2000 and 2003, and additional CO<sub>2</sub> is proposed to increase the buffering capacity of the lake water, to precipitate, and store carbonates in the lake sediments.

**Additional Key Words:** Mineral trapping, lake treatment

<sup>1</sup> Paper presented at the 7<sup>th</sup> International Conference on Acid Rock Drainage (ICARD), March 26-30, 2006, St. Louis MO. R.I. Barnhisel (ed.) Published by the American Society of Mining and Reclamation (ASMR), 3134 Montavesta Road, Lexington, KY 40502

<sup>2</sup> Florian Werner is leading a research group on post mining landscapes at the Dresden Groundwater Research Centre (DGFZ e.V.), Meraner Str. 10, 01217 Dresden, Germany.

<sup>3</sup>Bastian Graupner is PhD-Student at the Dresden Groundwater Research Centre. <sup>4</sup>Broder Merkel is Full Professor for Hydrogeology and Environmental Geology at the University Bergakademie Freiberg, 09599 Freiberg, Germany. <sup>5</sup>Christian Wolkersdorfer is Research Fellow at the University Bergakademie Freiberg

7<sup>th</sup> International Conference on Acid Rock Drainage, 2006 pp 2217-2353

DOI: 10.21000/JASMR06022344

<https://doi.org/10.21000/JASMR06022353>

## **Introduction**

A large number of Pit Lakes exists in the German Lausitz Mining District, where flooding with surface water and continued flushing is the main strategy to obtain an acceptable water quality. Nevertheless the discharge from some lakes, or the lakes themselves, needs to be treated before pit lake water can be discharged into rivers. Attempts to neutralize the large seasonally stratified (dimictic) lakes in this area has been with the addition of lime, ashes from combustion power plants or soda, which has provided mixed results.

The planning of a pit lake treatment needs to consider lake-internal and lake-external processes. The external processes are controlled by the interrelation with the groundwater flow system and the behavior of the slopes. As a result of lake-external processes a mass flux of dissolved constituents that is imported into the lake exists (Werner, Bilek, Luckner, 2001). The key parameter of this mass flux is acidity, defined as the acid generating potential treatment (Uhlmann, Büttcher, Schulze, 2004) and the intensity of this acidity flux controls the expected sustainability of a lake treatment.

Lake internal processes in the acidic Lausitz Pit Lakes are of hydrodynamic, chemical and biological nature. Biological processes in these lakes are dominated by microorganisms that are involved in the Fe and S cycle (Wendt-Potthoff and Koschorreck, 2004), whereas primary production is limited by the availability of P and C (Beulker and Nixdorf, 2004). The dominant chemical reactions in these acidic lakes are the oxidation of Fe and the precipitation of Fe containing solid phases (Peine 1998). Hydrodynamic mixing controls the transport of dissolved constituents within the lakes. The exchange of O<sub>2</sub> and CO<sub>2</sub> with the atmosphere across the surface boundary of the lakes is mainly controlled by the properties of the water surface (Vlahos et al. 1995) and the transport to and from surface near layers.

Pit Lake volumes in the Lausitz area range from 10 to 300 x 10<sup>6</sup> m<sup>3</sup>. Acidic lakes are often treated with lime by applying the lime directly onto the lake's surface (Evans and Dillon, 1995). In the Lausitz area, lime has recently been successfully applied to a lake by spraying a lime slurry with a nozzle used for agricultural irrigation onto the surface. The device was fitted on floating pipes and moved during operation, while the slurry was provided by a station located at the shore line (Scholz, 2005). The main problem in treating large bodies of water with lime (with a base consumption of several moles per m<sup>3</sup>) is to assure a sufficiently high flux of lime on the one hand and to avoid over saturation and massive sedimentation on the other hand.

## **Proposed Treatment Scheme**

The general concept is to combine CO<sub>2</sub> mineral trapping and the treatment of acidic mine waters by increasing alkalinity. In the Lausitz mining district intensive mining during the last century has produced large deposits of fly ash, C slurry, and Fe(OH)<sub>3</sub> sludge containing overdosed lime (from the treatment of acid mine drainage) in the abandoned and flooded mine pits. One of these former pits is the acidic Burghammer pit which contains large amounts of these substances deposited on its bottom (LMBV, 2003). In our opinion a treatment of lake Burghammer sediments and water with CO<sub>2</sub> appears thermodynamically feasible using carbonation. Kinetic aspects, the real world phase assemblage, and technical aspects of the dosage, mixing, precipitation, and settling of the carbonate solid will be investigated in the

project CDEAL (Geotechnologien 2005) during the next 3 years. An acidic water with a typical concentration of Ca (3 to 10 mmol/L) will cause a calcite saturation during a base titration if CO<sub>2</sub> is allowed to reach equilibrium concentrations. Calcite precipitation will reduce the Ca concentration as long as saturation is maintained and Dissolved Inorganic Carbon (DIC) concentration increases as pH rises and Ca concentrations decrease (Nordstrom and Munoz 1986, Bethke 1996). These considerations show that there is a potential for acidic lakes to uptake of CO<sub>2</sub> to the H<sub>2</sub>O if the treatment is combined with a neutralization of the H<sub>2</sub>O. Consequently the natural pH-buffer HCO<sub>3</sub><sup>-</sup> is introduced to the H<sub>2</sub>O and improves both the chemical condition and the biological potential.

The amount of calcite that can be precipitated if only pH is raised is of course low and dependant of the initial Ca concentrations of the H<sub>2</sub>O. Unlimited amounts of calcite can be produced if unlimited quantities of Ca and carbonate are delivered to the solution, precipitated calcite can be stored in the sediment, supported by the fact that lake sediments are natural calcite sinks in the geosphere. The storage mechanism consequently is not based on technical elements but rather on the geochemical conditions and calcite precipitation should not be used in lakes that have a longtime tendency of becoming acidic through geological setting. However, should the acidic conditions return to a lake used for calcite storage, this will not result in instantaneous CO<sub>2</sub> release. Dissolution of calcite will buffer imported acidity and improve the water quality but is not desirable in terms of C storage. A slow release of CO<sub>2</sub> is expected because the surface area (boundary sediment/lake) is small compared to the total mass of the sediment.

Furthermore, Fe precipitation, occurring during neutralization, is expected to act as a capping mechanism, which will limit exchange. Further Fe precipitation can produce sediment layers that support a progressive exclusion of the carbonates from participating in lake internal processes as the sediment consolidates. Active sediment capping is applied as a remediation technique to exclude contaminants in lake sediments from lake water (EPA 1993).

Hence calcite precipitation is best applied in acidic lakes that will be circum neutral after the initial water treatment. Lake Burghammer is part of a planned storage system, which will receive high fluxes of surface waters (LMBV 2003). A water treatment station at its inflow point can be used to maintain neutral conditions if necessary.

However the supply of cations (Ca, Mg) is a limiting factor for the utilization of the storage strategy. A positive effect concerning the overall CO<sub>2</sub> budget can be achieved using cations from the fly ashes of combustion power plants.

### Lake Burghammer

Lake Burghammer (Fig. 1 and 2) occupies an old mine pit, is located 5 km east of the city of Hoyerswerda in Saxony and is part of the river Spree catchment. The mining lakes, Dreiweibern, Lohsa II and Burghammer, are planned to be operated as a single storage pond system. The outflow out of this system will discharge from Lake Burghammer into the Kleine Spree River which is a tributary to the River Spree.

The lake is currently 72% full and its final water volume will be  $36 \cdot 10^6 \text{ m}^3$ . From 1974 to 1997 fly ash from the Schwarze Pumpe combustion power plant has been dumped in the abandoned surface mine, before the lake was flooded. During the years 2002 to 2003 a re-suspension of the dumped ashes was tested and demonstrated (Fig. 3), using an excavator on a floating platform equipped with a suction tube and a rinsing device (Fig. 4). It was shown that this re-suspension activity was successful in neutralizing the acidic lake water, but that no buffer

capacity could be built up in the water by this action (LMBV 2003). Consequently it was decided to postpone a further operation of the suction excavator until Lake Burghammer begins to discharge water into public streams (Kleine Spree River) and to keep an instrument of controlling the effluent pH.

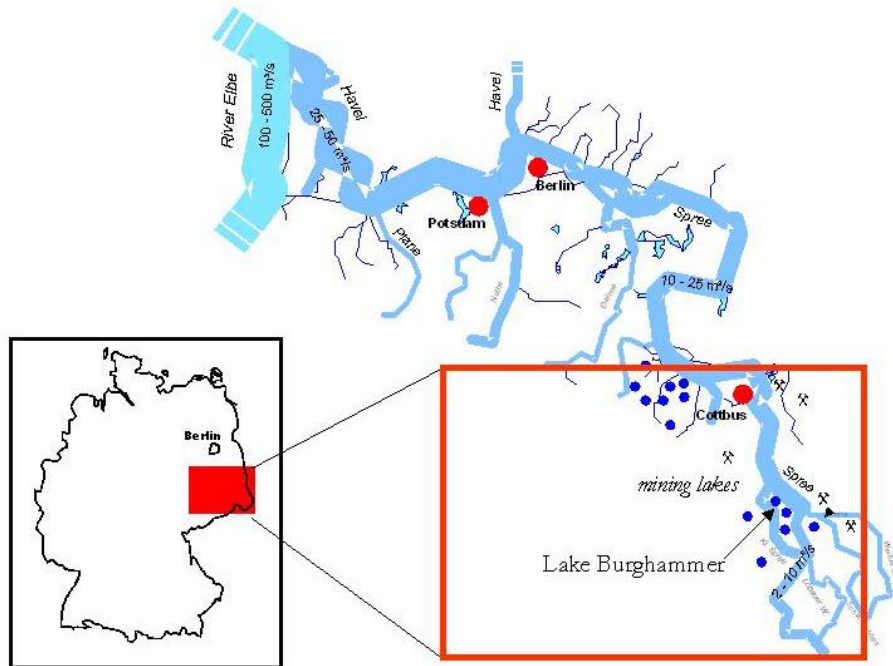

Figure 1. Map of Germany (left) showing the location of the Lausitz post mining area in the River Spree catchment and Lake Burghammer

Based on the presented cornerstones of the treatment scheme the authors propose the hypothesis, that the effects of the re-suspension of the alkaline sediments on the acidity of the lake water can be enhanced by the application of  $\text{CO}_2$  and that  $\text{CO}_2$  can be stored as carbonate on the lake bottom. To prove this hypothesis the presented study is conducted. The presentation is focused on the methods rather on results, as this study is still ongoing. The study will consider the effects of the treatment on a technical and a hydrological scale. These scales are addressed as internal and external processes.



Figure 2. Aerial view of lake Burghammer (courtesy of eta AG engineering Cottbus).



Figure 3. Re-suspension of fly ashes from the lake bottom without the use of CO<sub>2</sub> (courtesy of eta AG engineering Cottbus).



Figure 4. Excavator used in the re-suspension tests (courtesy of eta AG engineering Cottbus).

### Lake Internal Processes

The following solution composition was analyzed in the epilimnion of Lake Burghammer in 2004: pH 3.1, Na 3 mmol/L, Mg 2.5 mmol/L, K 0.5 mmol/L, Ca 9 mmol/L, C 0.2 mmol/L, S(6) 14 mmol/L, Fe 0.2 mmol/L, Cl 2.0 mmol/L. A stepwise simulation of the equilibrium processes that might occur was performed using PHREEQC2.7 ( Parkhurst an Appelo, 1999). In the first step CaO and CO<sub>2</sub> was dissolved into the water and calcite was allowed to precipitate. Then CO<sub>2</sub> was introduced by assigning a partial pressure of 2 bar, assuming a treatment depth of 10 m and the use of the CO<sub>2</sub> gas. In the second step this water was equilibrated with atmospheric CO<sub>2</sub> partial pressures to approximate the release of CO<sub>2</sub> from the treated water into the atmosphere (Tab. 1).

Table 1. Results of PHREEQC modelling with CO<sub>2</sub> partial pressure of 2 bar.

Step	CaO input	pCO <sub>2</sub>	CO <sub>2</sub>	Calcite	Ca	C	pH
	mmol/L	bar	in/out mmol/L	precip. mmol/L	in solution mmol/L	in solution mmol/L	in solution –
0	0	0.006	–	–	9	0.2	3.1
1	1000	2	1078	988	21	90	5.8
2	0	0.0004	-78	12	9.5	0.4	7.8

This rough calculation shows that calcite may precipitate in the same magnitude as CaO is dissolved in the water. The main influence of the partial pressure of CO<sub>2</sub> is the control of pH. Low pH favours CaO dissolution, but hinders calcite precipitation and CO<sub>2</sub> dissolution. A second calculation was performed with a pCO<sub>2</sub> of 0.1 bar (Tab. 2). Best results seem to be possible if CO<sub>2</sub> supply is controlled depending on the dissolution of CaO and the pH. The higher the pH in step 1 (the lower the partial pressures of CO<sub>2</sub> will be) the less CO<sub>2</sub> degasses unused into the atmosphere after the water equilibrates with atmospheric gases. In these calculation examples the unused fraction of CO<sub>2</sub> ranges from 0.6 to 7 %. Gypsum saturation was not exceeded in these examples.

Table 2. Results of PHREEQC modelling with CO<sub>2</sub> partial pressure at 0.1 bar.

Step	CaO input	pCO <sub>2</sub>	CO <sub>2</sub>	Calcite	Ca	C	pH
	mmol/L	bar	in/out mmol/L	precip. mmol/L	in solution mmol/L	in solution mmol/L	in solution –
0	0	0.006	–	–	9	0.2	3.1
1	1000	0.1	1006	997	12.5	10	6.5
2	0	0.0004	-6	3	9.5	0.4	7.8

The control of the mass fluxes during the reaction is a key task to provide thermodynamic preconditions for the turnover of  $\text{CO}_2$  into calcite. The rates for this reaction were studied by Plummer et al. (1978) and Kunz and Stumm (1984). They are reported as first order law with respect to the activity product  $a_{\text{Ca}^{+2}} \cdot a_{\text{HCO}_3^+}$ , the rate constant is given in  $\text{mmol CaCO}_3 \text{ cm}^{-2} \text{ s}^{-1}$ . An estimate of the expected rates cannot yet be given, as the surface area that will be available for nucleation is unknown. From the first sampling of the sediments, a Ca concentration released in the first step (adsorptive bound) of a sequential extraction (Zeien, 1995) of 1 to 2wt% was found.

#### Experimental setup to investigate the reaction processes

Samples from the fly ash deposits of Lake Burghammer are investigated by using batch and bench experiments. Batches with stirred water/ash suspensions and a gas head space to control  $\text{CO}_2$  partial pressures were set up (Fig. 5). It will be investigated if the solid phases that precipitate are the defined phases for which the thermodynamic data are available. The distribution of Ca in the solid and liquid phase will be analyzed. In addition C will be analyzed in the gas phase. Another aim of the experiments is to determine the reaction rates and the limiting reactions of the process. The batch experiment is designed in a way to minimize physical controlled transfer rates. The batch will be stirred to maximize the contact between the solid, liquid and gaseous phases. The influence of the Ca-source will be investigated by using sampled fly ash from the lake bottom and fresh fly ash from a combustion power plant.

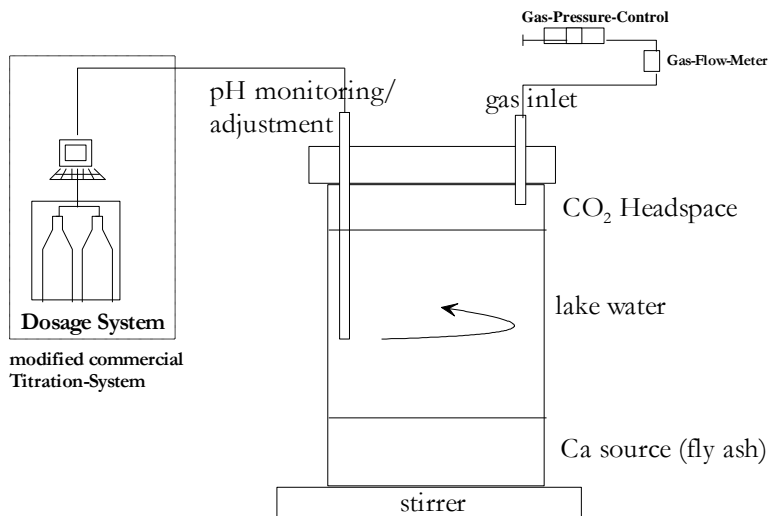

Figure 5: Sketch of the batch experiment setup

After a successful completion of the batch experiments the system will be scaled up to bench scale (Fig. 6) where the fly ash dissolution and the carbonate precipitation process are investigated with physical dimensions that are closer to reality, that is contact surfaces and contact times are maximized to exclude their influence. The field scale excavator on a floating platform equipped with a suction tube and a rinsing device is the scale that has to be bridged with the bench experiments. A key question investigated is whether the removal of  $\text{CO}_2$  and the supply of fly ash can achieve the same rate. If this can not be achieved in the bench experiments, a modification to the existing excavator technology must be considered. The layout for the

bench experiments is shown in Fig. 6. Apart from the strategy of transporting the reactants and using a technical reactor, the injection of  $\text{CO}_2$  into the ash is also considered.

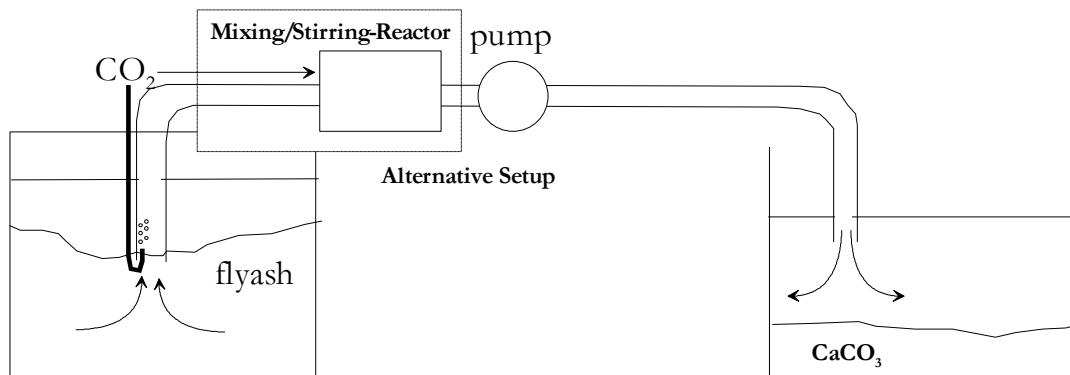

Figure 6: Sketch of the bench experiment setup

### Lake External Processes

The external processes to the lake that affect the sustainability of C storage within the water and the sediment are the ones that import acidity into the lake. The three sources of acidity are (i) the ground water influx, (ii) the leaching of the bank materials and (iii) the surface water inflow from upstream mining lakes and a small river. These fluxes have been investigated and predicted for the future hydrologic system by the owner of the lake (LMBV 2005). A regional ground water flow model and a reactive balancing approach were used for these predictions. The acid-base budget of the lake is, according to these findings, dominated by the operation of the surface water inflow from the upstream lakes. A treatment plant that neutralizes this inflow, with a maximum flow rate of  $10 \text{ m}^3/\text{s}$ , is planned to be built. This treatment plant will be able to maintain neutral conditions in Lake Burghammer. The existing modeling results concerning the future regional water and mass budget will be checked with recent data of the flooding process (surface water input, water quality). The mass budget calculations will be updated based on the existing flow model results (LMBV, Winkler). A prediction will be made how the proposed  $\text{CO}_2$  storage technology will work in Lake Burghammer as a whole and what effect this will pose on the lake water. The possibility of a re-dissolution of the precipitated calcite, which is closely connected to the future pH in the lake has to be considered. The predictive modeling will be performed with a model called MODGLUE (Müller 2004). Functionalities of existing and proven models were modified and extended to build a new model termed MODGLUE (MODEL for Prediction of Groundwater and Erosion influenced Lake Water Quality Using Existing Models). This interdisciplinary model integrates all major processes as well as their temporal and spacial interactions. The model was developed for acidified mining lakes. It incorporates a lake model (CEQUALW2, Cole and Buchak (1995)) that was modified to simulate acidic as well as neutral systems. Inorganic processes are simulated with PHREEQC. The model was programmed using object oriented programming schemes in the language PYTHON. To simulate the lake treatment/calcite storage a model of Lake Burghammer has to be set up and changes in the code have to be made.



## Conclusions

The proposed technology is not feasible for treating the CO<sub>2</sub> mass flux that is produced in lignite combustion power plants, as a whole. The amount of fly ash that is simultaneously produced with CO<sub>2</sub> is significantly less than would be required for a stoichiometric ratio of one to one. Nevertheless, this seems to be a strategy to bring benefits to both the CO<sub>2</sub> emitter and the water quality of acidic lakes, which strongly affects the public. Land use of post mining areas is connected to a good water quality of the surface and ground water. Accepting these limitations, the prospects of scientific and technical success are viewed to be high. The storage mechanism for CO<sub>2</sub> can be addressed as a low risk strategy. No instantaneous release is to be expected. An acidification of the deposit that might lead to dissolution of the deposit can be controlled by the technical means that will be installed to neutralize the influx from upstream lakes.

## Acknowledgement

We would like to thank the German Ministry for Education and Research (BMBF) for funding the project CDEAL within its GEOTECHNOLOGIEN program and the LMBV for supporting the project.

## Literature Cited

- Beukler, C., Nixdorf, B., 2004. Primärproduktion und Alkalinisierung. in: Nixdorf, B. und Deneke, R. (Hrsg): Grundlagen und Maßnahmen zur biogenen Alkalinisierung von sauren Tagebauseen. – Weißensee, Berlin. (Primary production and alkalinity production)
- Bethke, C.M. 1996. Geochemical Reaction Modelling, Oxford University Press
- Cole, T.M., Buchak E. M. 1995. CE-QUAL-W2: A Two-Dimensional, Laterally Averaged, Hydro-dynamic and Water Quality Model Version 2.0, US Army Corps of Engineers, Waterways Experiment Station.
- EPA, 1993. Selecting Remediation Techniques for Contaminated sediments. EPA 823-B93001. Office of Water (WH 585), 226 p.
- Evans, H. C. and Dillon P.J. 1995, Methods to Evaluate Whole Aquatic and Terrestrial Systems. in: Lindhurst, R.A., Bourdeau, P., Tardiff, R.G. (eds.): Methods to Assess the Effects of Chemicals On Ecosystems, Wiley
- Geotechnologien, 2005 »Science Report« No. 6:»Investigation, Utilization and Protection of the Underground«, Kick-Off-Meeting, BGR Hannover, 22-23-September 2005, Programme & Abstracts - Potsdam:Koordinierungsbüro GEOTECHNOLOGIEN, 2005, 144 p.
- Hupfer, M., Pöthig, R., Brüggemann, R., Geller, W. 2000. Mechanical resuspension of autochthonous calcite (Seekreide) failed to control internal phosphorus cycle in an eutrophic lake.- Wat. Res. 34, 3: 859-867. [http://dx.doi.org/10.1016/S0043-1354\(99\)00229-8](http://dx.doi.org/10.1016/S0043-1354(99)00229-8).
- Klapper, H. 1992. Eutrophierung und Gewässerschutz. – Fischer, Jena. (Eutrophication and water protection)
- LMBV, 2003. Restlochflutung. Maßnahmen zur Steuerung der Wasserbeschaffenheit in den Bergbaufolgebeseen der Lausitz. 72 p. unpublished paperback, edited by the Lausitzer und

- Mitteldeutsche Bergbau-Verwaltungsgesellschaft mbH. (Pit Lake Flooding- means to control the water quality of pit lakes in the Lausitz area)
- LMBV, 2005. Gutachten zur Entwicklung der Wasserbeschaffenheit in den Tagebauseen Dreiweibern, Lohsa II und Burghammer der Brandenburgischen TU Cottbus, unpublished study (Study on the expected changes of the water quality water in the pit lakes Dreiweibern, Lohsa II and Burghammer)
- Müller, M. 2004. Modellierung von Stofftransport und Reaktionen mit einem neuentwickeltem gekoppelten Grund- und Oberflächenwassermmodell am Beispiel eines Tagebaurestsees Proceedings of the DGFZ, Volume 25 (Modeling of transport and reactions with a newly developed ground- and surface water model at a post mining lake)
- Nordstrom, D.K. and Munoz, J.L. 1986. Geochemical Thermodynamics, Blackwell Scientific Publications.
- Parkhurst, D. L., Appelo, C. 1999. Users's Guide to PHREEQC (Version 2)–a Computer Program for Speciation, Reaction-Path, 1D-Transport, and Inverse Geochemical Calculations, U.S. Geological Survey. 312 p.
- Peine, A., 1998. Saure Restseen des Braunkohletagebaus- Charakterisierung und Quantifizierung biogeochemischer Prozesse und Abschätzung ihrer Bedeutung für die seeinterne Neutralisierung. Dissertation. Bayreuther Forum Ökologie, Band 62 (Characterisation and quantification of biogeochemical processes und estimation of their implication for lake internal neutralising)
- Scholz, G. 2005. Inlake-Technik- ein effizientes Verfahren zur Alkalinisierung und Sulfatreduzierung schwefelsaurer Tagebauseen. Tagungsband des 56. Berg- und Hüttenmännischen Tag, Freiberg (In-lake techniques- an efficient way to input alkaline and reduce sulfate concentrations for acidic mining lakes)
- Uhlmann, W. , Büttchner, H. Schulze, M. 2004. Grundlagen der chemischen und biologischen Alkalinisierung saurer Tagebauseen, in: Nixdorf, B. und Deneke, R. (Hrsg): Grundlagen und Maßnahmen zur biogenen Alkalinisierung von sauren Tagebauseen. – Weißensee, Berlin. (Chemical and biological alkalinity input into acidic post mining lakes)
- Wendt-Potthoff, K. and Koschorreck, M. 2004., Mikrobielle Gemeinschaften und Stoffumsätze in sauren Tagebaugewässern in: Nixdorf, B. und Deneke, R. (Hrsg): Grundlagen und Maßnahmen zur biogenen Alkalinisierung von sauren Tagebauseen. – Weißensee, Berlin. (Microbial communities and turnover rates in acidic post mining lakes)
- Vlahos , P., Mackay, D., Eisenreich, S.J. and Hornbuckle, K.C. 1995. Exchange of Chemicals Between the Athmosphere and Lakes. in Lerman. A. and Imboden, D. (Eds.) Physics and Chemistry of Lakes. 2. ed., Springer Verlag, Berlin.
- Werner, F., Bilek F., Luckner, L. 2001: Implications of Predicted Hydrologic Changes on Lake Senftenberg as Calculated Using Water and Reactive Mass Budgets, Mine Water and the Environment, Journal of the International Mine Water Association, Volume 20, Number 3
- Zeien, Hermann (1995): "Chemische Extraktionen zur Bestimmung der Bindungsformen von Schwermetallen in Böden", Bonner Bodenkundliche Abhandlungen, 17, Institut für Bodenkunde, Bonn, ISSN 0939-7809