

# Development of a Model Study for Deep Tillage with Air and Material Injection<sup>1</sup>

by

Debra L. Simpson, Richard J. Sweigard, and Lee W. Saperstein<sup>2</sup>

## Abstract

Current reclamation regulations require the removal, replacement and protection of topsoil and subsoil at a surface coal mine. One consequence of soil transportation includes subsequent compaction. This is a common problem encountered on reclaimed mine soils since the establishment of permanent vegetation is required. Deep tillage is a technique aimed at reducing the undesirable effects of compaction. Several studies on undisturbed soil have shown that the benefits of deep tillage are usually short-lived. The pore space created by tillage operations is reduced due to subsequent cultivation. A model study has been conducted to investigate the feasibility of injecting organic material into the voids to prevent recompaction. This paper addresses the development of the laboratory model and testing procedures. Included will be consideration given to selection of an air and material injection system, ripping tool and soil analysis techniques. The primary soil characteristics that were measured in the laboratory were bulk density (both gravimetric and nuclear methods were used), mechanical resistance (measured with a recording cone penetrometer) and saturated hydraulic conductivity.

## Introduction

A highly compacted soil reduces root growth, which in turn reduces crop yields. In addition, several soil properties change as a result of soil compaction. Soil density increases as the soil particles move closer together. The mechanical resistance to penetration increases, depending on moisture content and size of

soil grains. The hydraulic conductivity is reduced due to an increase in compaction (Barnhisel, 1988).

## Recompaction

Subsequent to an area being deep tilled, certain events will reduce the pore space created by tillage operations. Several studies have been conducted on recompaction of deep tilled soils located on areas undisturbed by mining. Larney and Fortune (1986) studied the effects of subsequent cultivation on a previously tilled area. Kouwenhoven (1986) studied the effects of natural events, such as rain, gravity and shrinkage on tilled areas. The problem of recompaction on a freshly tilled soil is due primarily to traffic that is necessary to prepare a seedbed.

The structure of a pretilled soil was found to affect its ability to recompact. When a dense, massive soil is deep tilled it will break up into large clods, which will need to be further worked to prepare a desirable tilth for seed germination. Poorly structured or massive soils, such as one would find on a typical reclaimed minesite, are likely to need additional cultivation in order to prepare an adequate seedbed. While these massive soils have the greatest need for deep loosening, the additional cultivation passes required for clod breakup canceled the effects of deep tillage (Larney and Fortune, 1986). Even without traffic, some of the newly created macropores will collapse due to natural events such as rainfall, gravity and shrinkage (Kouwenhoven, 1985).

Recompaction of reclaimed mine soils has been documented as a byproduct of other investigations. In work conducted by Barnhisel (1986) there was a

---

<sup>1</sup> Paper presented at the 1991 National Meeting of the American Society for Surface Mining and Reclamation, Durango, Colorado, May 14-17, 1991.

<sup>2</sup>Debra L. Simpson is a graduate assistant in the Department of Mining Engineering, University of Kentucky, Lexington, KY. Richard J. Sweigard is Associate Professor of Mining Engineering, University of Kentucky, Lexington, KY. Lee W. Saperstein is Professor and Chairman of Mining Engineering, University of Kentucky, Lexington, KY.

tendency for the bulk density to increase over a period of two years after initial ripping and subsequent traffic on field soils. The cause of the increase was not investigated. Documentation of laboratory studies involving recompaction of typical mine soils has not been found.

### Development of the Physical Model

A model compaction study was developed to investigate the effect that material injection has on the recompaction of a deep tilled soil. This paper addresses the development of the laboratory model and testing procedures (See Figure 1).

### System Components

The major components of the model used in this experiment consisted of:

- soil bin
- air pallet
- Giddings soil probe
- tillage tool (ripper)
- air and material injection unit (sandblaster)
- nuclear density/moisture gage
- cone penetrometer and data acquisition system
- permeameter

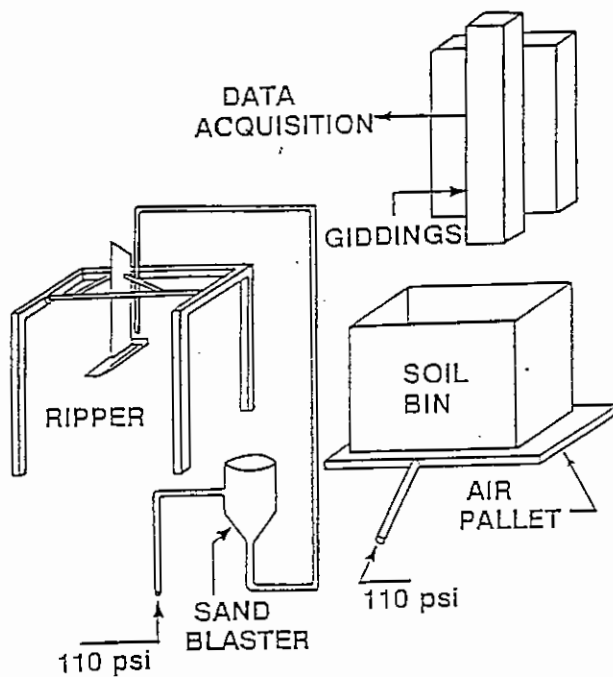

FIGURE 1. Overview of model system.

The soil bin served as the containment unit and measured 91.4 cm by 121.9 cm (36.0 in by 48.0 in) in plan view and 91.4 cm (36.0 in) deep. The air pallet provided a means of positioning the bin as needed for various tests, which will be described later in this paper. A Giddings soil probe was used to extract samples for bulk density determination and, with some modification, was used to drive a recording cone penetrometer. Compaction and recompaction were also accomplished with the Giddings. A flat plate was machined measuring 30.5 cm by 30.5 cm (12.0 in by 12.0 in) and attached to the shaft of the Giddings. As the shaft was lowered, the soil was compressed under the plate. The maximum applied force was 22 kN (5000 lb). A standard farm implement was selected to represent a field ripper. The ripper was mounted on a frame and pushed with a hydraulic cylinder. The cylinder has a stroke of 91 cm (36 in) and a maximum force of 218 kN (49,000 lb). The selected air and material injection system was a conventional sandblaster. (See Figure 2). The sandblaster is a pressurized tank in which pressurized air enters the tank near the top and, working with gravity, forces material through the funnel-shaped outlet at the base. The material is then conveyed pneumatically through the hose.

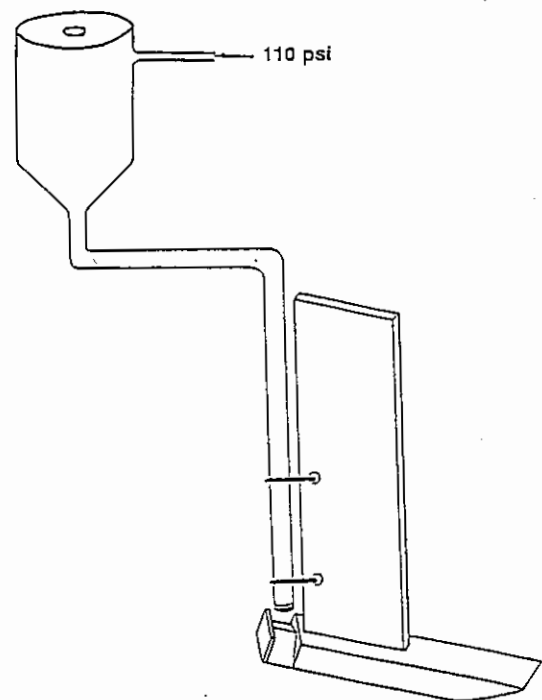

FIGURE 2. Air, material injection system.

The hose outlet was located at the rear of the ripper immediately above an inverted "V" shape which was

machined on the ripper foot. To prevent an excess of material exiting the path of the ripper, a shield was also machined as a part of the ripper foot. A number of organic materials were tried but crushed walnut shells and pecan shells worked best with this system.

**Similitude.** The concept of similar systems was considered to scale field tillage equipment for use in the laboratory. The relationship between the field system and the laboratory system model was determined since the same physical laws govern the behavior of both systems. The similarity considerations are geometric (ripper dimensions), dynamic (ripper speed and acceleration) and kinematic (soil failure patterns). The kinematic similarity requirement depends upon the geometric and dynamic similarity (Wismer, Freitag, Schafer, 1976). The important variables to be modeled are the ratio of the operating-depth-to-the-cutting-width of the ripping tool and angle of the ripper foot off the horizontal (rake angle) (See Figure 3). These two dimensionless ratios describe the phenomenon of soil failure, all other variables (soil and operating conditions) remaining the same. The volume of failure, represented by the three pie-shaped pieces in Figure 3 was determined with a mathematical model. The model ripper had a D/W ratio of 6 and a rake angle of  $.128 \pi$  rad (23 degrees).

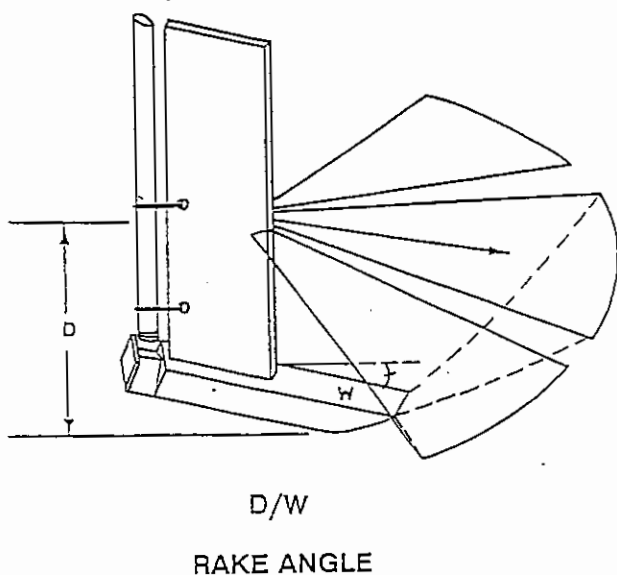

FIGURE 3. Selected tillage tool showing volume of failure and pertinent variables.

The effect of ripper speed on soil failure patterns was investigated by Stafford (1979). At very low speeds, 5 mm/s (.02 in/s), the soil failed in a manner similar to failure under field ripping speeds. At very high ripping

speeds, 5 m/s (16 ft/s), a change in failure occurred, from shear failure to plastic flow. This change occurred at a critical velocity known as the plastic propagation velocity. Therefore, soil reactions were found to be rate dependent at very high velocities. However, typical field and laboratory ripping speeds fall well below this upper limit. The model ripper used in this study had a velocity of approximately 2 cm/s (.78 in/s), which may reasonably develop failure patterns similar to field ripping speeds.

**Soil Failure Patterns.** When a ripper is forced through the soil, the resulting failure is assumed to follow the Mohr-Coulomb failure criterion for moisture contents less than the plastic limit. The soil is pushed outward and upward in the shape of a crescent, thus termed crescent failure. Generally, a ripper with a small depth-to-width ratio, such as the laboratory model, develops crescent failure over the entire working depth. As the depth-to-width ratio is increased, usually by increasing the operating depth, the crescent failure is limited to a region above a critical depth. Below this critical depth, the soil moves laterally. Any changes in soil characteristics (i.e., density, angle of internal friction and moisture content) as well as ripper configuration and operating variables will affect the critical depth (Godwin and Spoor, 1977). The rake angle has a similar effect of increasing or decreasing the depth of crescent failure. Generally, when the rake angle is decreased, the depth of crescent failure is increased (Payne, 1959).

**Tillage Tool Selection.** The model ripping tool was selected to loosen the soil within the confines of the bin with an operating depth of 30.5 cm (12.0 in). To minimize the reaction with the bin walls, the edge of the surface disturbance was designed to extend approximately 23 cm (9 in) on either side of the ripper (Godwin and Spoor, 1977). A buffer of undisturbed area, measuring approximately 38 cm (15 in), was located between the bin wall and the ripped zone on each side of the ripper. The actual width of surface disturbance was observed to be approximately 46 to 56 cm (18 to 22 in).

### Experimental Design and Procedure

This study was designed to determine the effect of material injection on the recompaction of prime farmland subsoil. A completely randomized design was selected. A total of ten experimental units (i.e., bins of soil) were prepared. Two bins, the first and the last, were for control. In order to ensure homogeneity of the experimental units, pertinent factors were held constant throughout the process of bin replications. These

factors were soil type, applied load, soil moisture, depth-to-width ratio, and rake angle of the ripper. The component introduced into the experiment was the material, which was injected during ripping. The area of study concentrated on the ripped zone. The number of samples extracted was determined by the physical limitations of the soil bin. The targeted pressure under the flat plate was set at 124-138 kPa (18-20 psi). This pressure range is typically found in the field under dozer tracks, depending on the size (Barnhisel, 1988).

There were three stages of each bin replication. After initial compaction, samples were taken for bulk density, moisture content, penetrometer soil strength and hydraulic conductivity. The sandblasting hose was then attached to the ripper shank with the hose outlet located at the rear of the ripper foot. Organic material was then injected into the soil with the sandblaster while being ripped. After ripping, samples were taken for the same parameters. Then the soil was recompacted at a uniform pressure. The targeted recompacted pressure was set at 83-96 kPa (12-14 psi). Again, samples were taken for the same parameters. These parameters describe the physical condition of the soil.

### Soil Analysis Techniques

The two methods used to test for bulk density were the gravimetric method and nuclear gage method. Soil core samples were taken with a split-barrel sampler, sliced, measured, weighed, oven-dried and reweighed to obtain density and moisture readings, gravimetrically. Duplicate samples were taken from each 15.2 cm (6.0 in) layer down to 45.7 cm (18.0 in). Dry bulk density is defined as the dry soil weight/wet volume and is expressed as  $g/cm^3$  ( $lb/ft^3$ ). A CPN Model MC-S-24 dual probe nuclear gage was also used. Gamma photons were emitted from the source probe and detected with the second probe. The probes were lowered into the prepared access holes and duplicate readings were taken at 5 cm (2 in) intervals down to 45.7 cm (18.0 in) (See Figure 4).

The core samples taken for gravimetric bulk density were retained to be tested further for saturated hydraulic conductivity. One sample was tested for each 15 cm (6 in) interval.

Resistance to penetration was tested with the cone penetrometer which was hydraulically driven with a Giddings soil probe. The resistance was found for a continuous interval of 45.7 cm (18.0 in) and recorded with a computerized data acquisition system (See Figure 5).

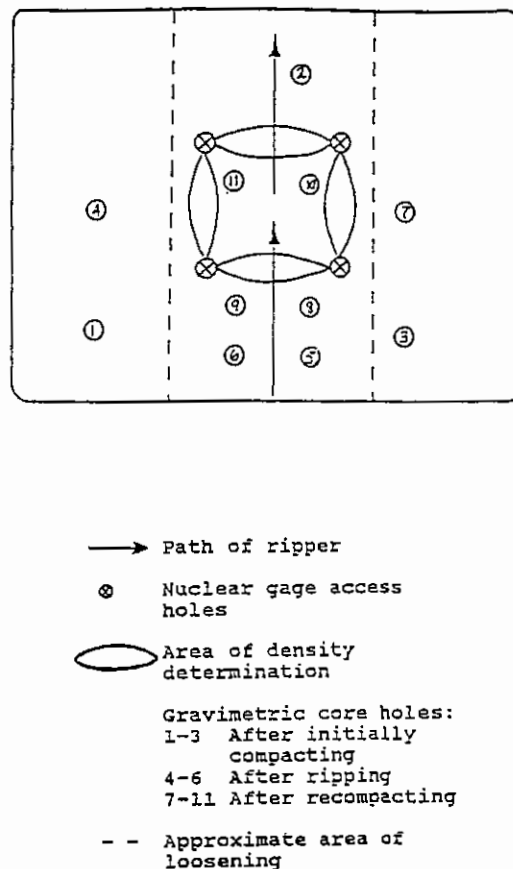

FIGURE 4. Sampling pattern for density.

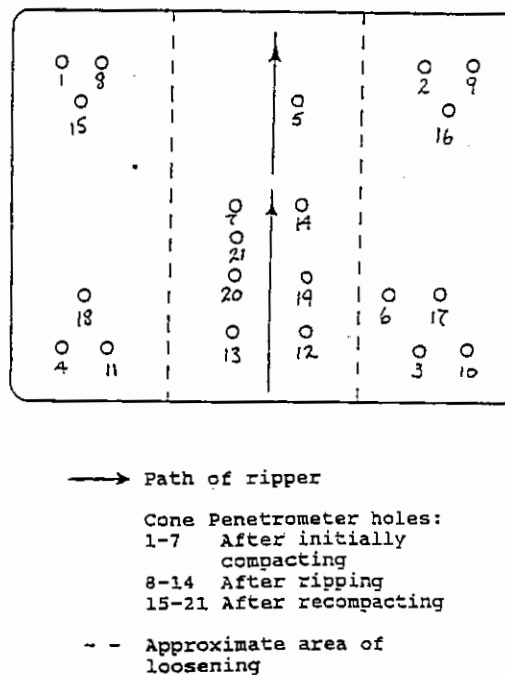

FIGURE 5. Sampling pattern for cone penetrometer soil strength.

## Discussion of Results

The goal of the soil analysis program was to document any residual effects of ripping and material injection following recompaction. For the purpose of discussion, the various soil analysis techniques can be categorized into two groups. The first group is vertically oriented measurements, which includes gravimetric bulk density, hydraulic conductivity, and penetrometer resistance. In evaluating these properties, either a sample is extracted and subjected to testing, as in the cases of gravimetric bulk density and hydraulic conductivity, or a measurement is taken in place at a specific point. This is the case for penetrometer resistance. Even though resistance was measured over a distance of approximately 45.7 cm (12.0 in), each run consisted of many closely spaced individual measurements of resistance as the cone advanced. These individual measurements were averaged in intervals of 15.2 cm (6.0 in).

The second category of soil analysis can be termed horizontally oriented measurements. In this method the bulk density that was determined represented a continuum of material between the probes, a distance of 30.5 cm (12 in) in this case.

This distinction between vertically oriented measurements and horizontally oriented measurements is significant due to the nature of the disturbance that was being studied. As described earlier, the ripping process results in a crescent failure pattern. This implies that strain occurs in the soil until the shear strength is exceeded and then a crescent forms. This process is repeated over the entire length of travel. Therefore, rather than forming continuous fracture planes in the soil, ripping results in somewhat regularly spaced failure surfaces that are curved nominally upward. Deposition of injected material was observed along many of these failure surfaces. The complication arose from trying to evaluate the residual effects with vertically oriented samples. Simple space limitations precluded taking a large number of samples at each stage of the experiment since measurements had to be carried out after initial compaction, following ripping and injection, and then again after recompaction. Data collection was limited by the small volume of failure. When extracting samples or taking penetration readings in the failure zone, it was difficult to predict which samples would intersect the zone of material injection. In a few cases hydraulic conductivity measurements indicated a residual effect following recompaction when compared to the initially compacted condition for the specified compactive efforts (See Table 1). This is

attributed to the fortuitous location of the samples because other tests did not indicate this positive increase in permeability.

However, since the nuclear bulk density measurements spanned most of the ripped zone, they did demonstrate a positive residual effect in several cases. Table 2 lists the nuclear bulk density measurements and gravimetric bulk density measurements taken at three depths within the crescent failure zone. From the nuclear bulk density measurements it is apparent that ripping and material injection had the overall effect of reducing bulk density. This is seen when bulk densities in the upper 30.5 cm (12.0 in) are compared to the bottom 15.2 cm (6.0 in). Bulk density decreased with ripping and then increased somewhat during recompaction. However, in the lower 15.2 cm (6 in) zone, which was below the effective depth of the ripper, bulk density tended to increase throughout the entire process.

## Summary

The physical model was developed to determine the feasibility of injecting various soil amendments into the voids by the use of air pressure. This basic goal was accomplished. The mitigating effect that material injection has on the recompaction of a deep tilled soil is initially encouraging. Comparisons to baseline data are currently underway. Additional tests with an improved pneumatic delivery system and other types of soil amendments are required to verify these initial results.

## REFERENCES

- Barnhisel, R.I., Powell, J.L., Hines, D.H., 1986, "Changes in Chemical and Physical Properties of Two Soils in the Process of Surface Mining," Transactions, American Society for Surface Mining and Reclamation.  
<http://dx.doi.org/10.21000/JASMR87010313>
- Kouwenhoven, J.K., 1985, "Model Studies on Upheaval and Reconsolidation of Tilled Soils in a Laboratory Soil Bin," Soil & Tillage Research, Vol.8, Dec., pp. 289-302.
- Larney, F.J. and Fortune, R.A., 1986, "Recompaction Effects of Mouldboard Ploughing and Seedbed Cultivation on Four Deep Loosened Soils," Soil & Tillage Research, Vol. 8, Jan., pp. 77-87.  
[http://dx.doi.org/10.1016/0167-1987\(86\)90324-7](http://dx.doi.org/10.1016/0167-1987(86)90324-7)
- Payne, P.C.J. and Tanner, D. W., 1959, "The Relationship between Rake Angle and the Performance of Simple Cultivation Implements,"



Journal of Agricultural Engineering Research,  
Vol. 4, pp. 312- 325.

Stafford, J., 1979, "The Performance of a Rigid Tine  
in Relation to Soil Properties and Speed," Journal  
of Agricultural Engineering Research, Vol. 24,  
Aug., pp. 41-56.

[http://dx.doi.org/10.1016/0021-8634\(79\)90059-3](http://dx.doi.org/10.1016/0021-8634(79)90059-3)

Wismer, R., Freitag, D., Schafer, R., 1976,  
"Application of Similitude to Soil-Machine  
Systems," Journal of Terramechanics, Vol. 13, #3,  
pp. 153-182.

[http://dx.doi.org/10.1016/0022-4898\(76\)90004-5](http://dx.doi.org/10.1016/0022-4898(76)90004-5)

Godwin, R.J. and Spoor, G., 1977, "Soil Failure with  
Narrow Tines," Journal of Agricultural  
Engineering Research, Vol. 22, Jan., pp. 213-228.

[http://dx.doi.org/10.1016/0021-8634\(77\)90044-0](http://dx.doi.org/10.1016/0021-8634(77)90044-0)

Table 1

Trial S2  
Hydraulic Conductivity  
(  $\times 10^{-5}$  cm/sec)

Position	After Compaction	After Ripping	After Recompaction
1T	1.7	2.2	3.3
1M	2.0	---	2.7
1B	---	2.6	---
2T	1.9	10.0 W,C	---
2M	1.4	2.7	2.7
2B	---	---	---
3T	0.7	---	1.4 W
3M	0.8	3.5 W	2.5
3B	2.2	2.8	---

T = Top sample (0-15.2 cm (0-6.0 in) below surface, average of duplicates)

M = Middle sample (15.2-30.5 cm (6.0-12.0 in) below surface, average of duplicates)

B = Bottom sample (30.5-45.7 cm (12.0-18.0 in) below surface, average of duplicates)

Position #1 is located outside the ripped zone.

Positions #2 and 3 are located within the ripped zone.

C = Sample was taken in crescent failure area.

W = Walnut Shells were found in core.

Table 2

Trial S4  
Gravimetric Bulk Density  
(g/cm<sup>3</sup>)

Position	After Compaction	After Ripping	After Recompaction
2T	1.63	1.57 C	1.60 M+C
2M	1.68	1.67	1.68
2B	1.68	1.69	1.70
3T	1.55	1.65 M+C	1.66 M+C
3M	1.65	1.78	1.66
3B	1.66	1.70	1.70

Nuclear Bulk Density  
(g/cm<sup>3</sup>)

Position	After Compaction	After Ripping	After Recompaction
1T	1.58	1.26 C	1.56 C
1M	1.65	1.32 M+P	1.54 M+P
1B	1.67	1.68	1.73
2T	1.59	1.29 M+C	1.42 M+C
2M	1.64	1.27 M+P	1.47 M+P
2B	1.67	1.71	1.73
3T	1.62	1.23 M+C	1.44 M+C
3M	1.64	1.27 M+P	1.52 M+P
3B	1.67	1.68	1.73

T = Top sample 0-15.2 cm (0-6.0 in) below surface

M = Middle sample 15.2-30.5 cm (6.0-12.0 in) below surface

B = Bottom sample 30.5-45.7 cm (12.0-18.0 in) below surface (also below depth affected by ripping)

C = Crescent failure area, no material in crescent area

M+C = Organic material was located in crescent failure area

M+P = Organic material was located in the path of the subsoiler

