

DEVELOPING WASTE-PILE SLOPE DESIGN CRITERIA
FOR STEEP-PLANE SLOPES:
JACKPILE URANIUM MINE RECLAMATION PROJECT¹

by

Michael J. Bone, P.E., and James H. Olsen, Jr., P.E.²

Abstract. The challenge of the Jackpile Reclamation Project was the need for quick development of necessary design changes that would harmonize with a rapidly proceeding construction effort. This paper describes the development of waste-pile slope design criteria for generic application to provide needed erosional stability to the design. Of specific interest was the method used to estimate the drainage area applied to the base of steep-plane slopes. A realistic approach was developed to account for the effect of rill development upon contributory drainage.

Additional Key Words: reclamation criteria, erosional stability, waste pile, draining terrace, slope length, drainage width, rill development, contributory drainage.

Introduction

The Jackpile-Paguate Uranium Mine was, in the late 1970s, the largest surface/underground uranium mining complex in the world. The operation is located on the Laguna Indian Reservation in west-central New Mexico, approximately 40 miles west of Albuquerque. It was operated by the Anaconda Company (later a subsidiary of the Atlantic-Richfield Company) from 1953 to 1982.

An estimated 400 million tons of earth were moved during the 29 years of mine operation, and approximately 2,656 acres of

land were disturbed during its operation. The disturbed areas include 3 open pits, 32 overburden waste piles, 23 protore (low-grade ore) stockpiles, 4 topsoil stockpiles, and 240 acres of support facilities and depleted ore stockpiles.

When the operation was closed, the environmental impacts for reclaiming the site were identified and evaluated in an Environmental Impact Statement (EIS) prepared by the Department of the Interior (DOI) as a joint effort between the Bureau of Indian Affairs (BIA) and the Bureau of Land Management (BLM) on behalf of the Pueblo of Laguna (DOI 1986a). This step was taken since no specific reclamation requirements or environmental standards for uranium mines existed. The operation also pre-dated any environmental assessment that may have been required in the 1970s and 1980s. Upon completion, a Record of Decision (ROD) was published (DOI 1986b), outlining the intent of the reclamation effort and some of the specific requirements for achieving the various goals.

¹ Paper presented at the 1991 National Meeting of the American Society for Surface Mining and Reclamation, Durango, Colorado, May 14-17, 1991.

² Michael J. Bone, P.E., Engineering Section Manager, Roy F. Weston, Inc., Albuquerque, NM 87108; and James H. Olsen, Jr. P.E., Reclamation Project Manager, Pueblo of Laguna, Laguna, NM 87026.

Record of Decision Waste Pile Criteria

For purposes of this paper, the relevant reclamation criteria cited in the ROD for the waste piles are summarized as follows:

- slopes will be reduced to 3h:1v or less;
- waste piles will be covered with 18 in of topsoil;
- berms will be installed on all crests to control erosion;
- tops will slope slightly away from their outer slopes;
- slopes will be contoured so their toes are convex, to prevent formation of major gullies on slopes; and
- after applying top soil, slopes will be fertilized, disked to a depth of 8 in, and then contour-furrowed.

Site Background

The primary basis for the ROD criteria stems from geotechnical slope stability being a major consideration of the EIS evaluation. However, slope failures due to slope instability have not been observed in the field. There are many examples of waste piles 25- to 30-years-old with angle-of-repose slopes that have shown no evidence of slope instability.

In retrospect, though, many waste pile slopes reflect rill and gully erosion. This instability has been due to a lack of stormwater runoff control. Large washouts have occurred on several waste piles due to uncontrolled ponding of runoff at waste pile crests that has breached and carried large quantities of soil down the steep slopes:

The installation of 3h:1v slopes on waste piles raised the most critical concern because of the increase to slope lengths. Many waste piles are 200 to 300 ft high, which will produce slope lengths of 600 to 900 ft. These long slopes were initially designed without runoff-control measures that would have intercepted and diverted runoff down the

long slopes. A redesign effort was initiated to reduce slope lengths by installing draining terraces. Construction was already proceeding at a rapid pace, however, which necessitated the need for a design that retrofitted the draining terraces into the 3h:1v slopes.

Erosional Stability Considerations

Soil erosion is the detachment and movement of soil by the action of water, ice, gravity, or wind (EPA 1976). Of these actions, erosion by water is by far the problem most frequently encountered. This is the case at the Jackpile-Paguete uranium mine. The basic types of overland erosion by water are splash or sheet, rill, and gully. The factors that influence the erosion potential of an area include climate, soil characteristics, topography, and ground cover (Goldman et al 1986).

Runoff Control

Soil erosion is primarily prevented by controlling stormwater runoff, its principal cause. Stormwater runoff control is achieved through the proper use of vegetative and structural practices. Proper stormwater handling can be accomplished by one or more of the following measures:

- reduction and detention,
- interception and diversion, and
- handling and disposal of concentrated flows.

Reduction and Detention

Reductions in both the amount and speed of runoff can be accomplished by manipulating the surface soil to detain and increase infiltration of runoff, and by manipulating slope length and gradient to reduce the velocity and rate of runoff. Manipulation of the surface soil includes roughening and loosening the soil, adding topsoil and soil amendment, and mulching and revegetation. With regard to slope and gradient, slope design should be based on the erodibility of the surface soils as well as stability against slope failure.

Interception and Diversion

Intercepting and diverting runoff before it can build up and concentrate is a critical measure in controlling soil erosion. This can be accomplished through the use of various diversion structures, including reverse benches or terraces, ditches, earth dikes, and combined ditches and dikes.

Handling and Disposal of Concentrated Flows

Interception and diversion of runoff will necessitate the handling and disposal of concentrated flow. Proper techniques applicable for the Jackpile-Paguante waste piles include spreading the concentrated flow into a wider flat area to dissipate the flow and to create a non-erosive sheet flow, and diverting the flows into a high wall to act as an energy dissipater.

Hydrology/Hydraulics

In terms of erosion and soil loss, an analysis of the critical parameters affecting hydrology and hydraulics was necessary for appropriate runoff control to be determined for the Jackpile-Paguante waste piles. Determination of the following parameters was necessary for this evaluation:

Hydrology

- runoff coefficients
- rainfall intensity
- drainage area (slope length and effective drainage width)

Hydraulics

- maximum allowable flow velocities
- Manning's roughness coefficient
- drainage slope
- flow depth
- allowable effective drainage width

Due to the range of possible field conditions, the evaluation developed a range of results to understand the sensitivity of the

parameters. Knowing the sensitivity of parameters is as important as knowing the actual values. Based upon this sensitivity evaluation, a conservative choice of parameters was made to complete the analysis and recommend specific design criteria.

Methodology

The methodology of this evaluation uses a maximum-allowable flow velocity to back calculate a maximum-allowable effective drainage width. Effective drainage width is a concept that recognizes increased contributory drainage area to a 1-ft base-of-slope segment as a result of rill and gully network development.

The effect of slope on the development of rills was investigated by Mosley (1972). Results of his investigation were used to estimate the average effective width of contributory drainage from a rill/gully unit.

This concept is illustrated in Figure 1. Estimated values of effective drainage width were compared to the allowable values to determine stable slope lengths for different degrees of slope.

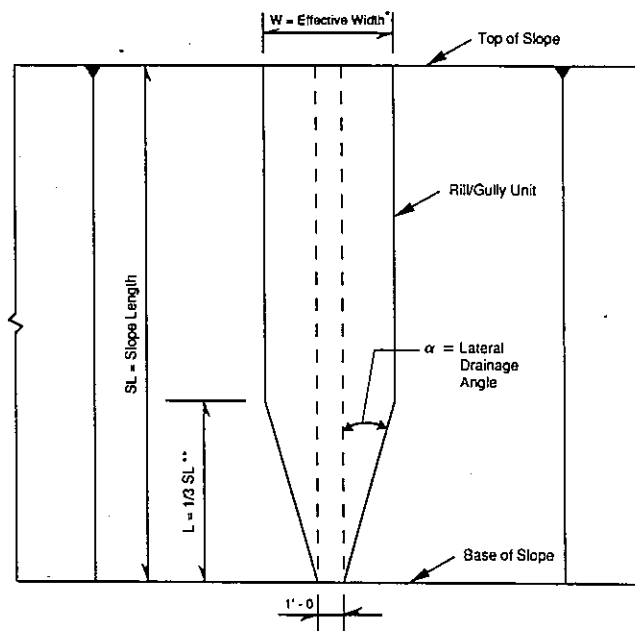

NOTE:

* Effective width is defined as the fully developed width of a rill/gully unit that contributes drainage to a 1' - 0 segment at the base of the slope.

** Lateral degree of spread assumed to reach effective width at one third the slope length.

Figure 1. Rill and gully effective drainage width.

Two critical variables are necessary to determine contributory drainage area by this concept: the lateral drainage angle and the point at which the rill/gully units stop spreading and become parallel.

Parameter Values

The hydrologic portion of this analysis was performed using the rational method (AISI 1971), in which

$$Q = c i A,$$

where

- Q = peak rate of runoff (cfs),
- c = runoff coefficient,
= 0.50 to 0.75
(Goldman et al 1986)
- i = rainfall intensity, and
= 6.89 in/hr (100-year return)
- A = drainage area (acres)

Due to the short times of concentration for flow off the slopes, the simplistic and empirical nature of this method was deemed more suitable.

The hydraulic analysis used Manning's equation and assumed a 1-ft-lineal segment at

the slope base to be a channel. The values or ranges used for Manning's equation are listed as follows:

$$Q = VA = A \frac{1.486}{n} R^{2/3} S^{1/2},$$

where

- V = flow velocity ≤ 3.0 fps,
- A = cross-sectional area of flow (sf),
- R = hydraulic radius (feet),
= depth of flow for a 1-ft wide channel
- n = Manning's roughness coefficient, and
= 0.025 to 0.035
- S = slope = 3h:1v and 2h:1v

The primary parameter from the equations above used to determine this evaluation is that of contributory drainage for steep-plane slopes.

Drainage Area

As discussed in the methodology, the key to determining a realistic drainage area for a plane slope is estimating an effective drainage width, as shown in Figure 1. The work by Mosley (1972) investigated rill development for different slopes, as partially illustrated in Figure 2.

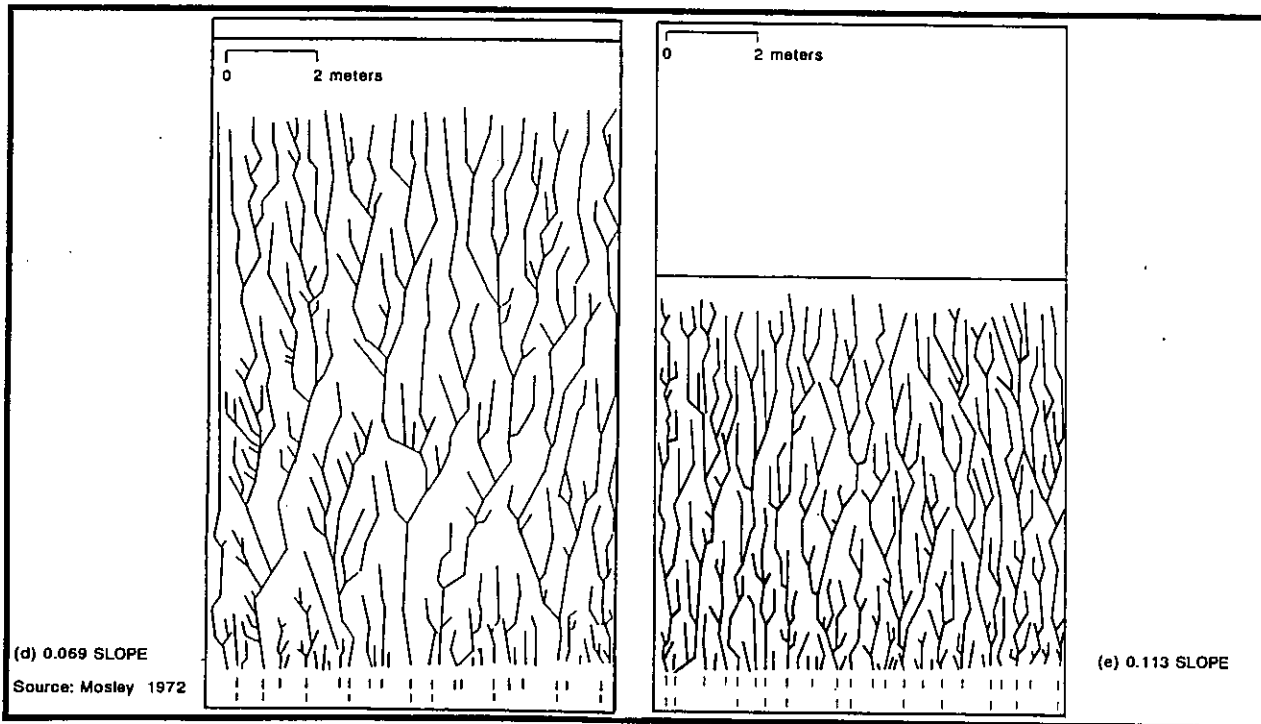

Figure 2. Rill development on plane surfaces.

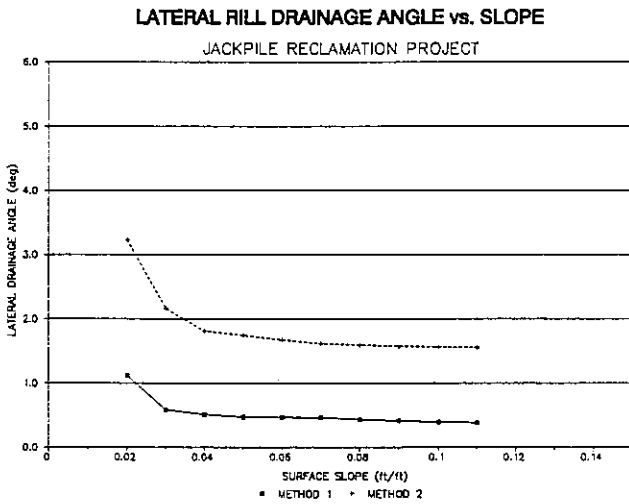

Table 1. Lateral rill drainage angle vs. slope.

The experimental chamber used by Mosely (1972) had a constant width of 30.2 ft with varied lengths depending on the gradient used. The number of gullies in each case was counted by 2 methods for this evaluation. The first method included both primary and secondary gullies, as counted by Mosley. The

second method took a more conservative approach and counted only the primary rill networks. The chamber width was divided by the number of gullies in each case to formulate an average effective width. The lateral spread angle was calculated using the average effective width and assuming the chamber length was L, as shown in Figure 1. The results of this analysis are illustrated in Table 1. Results indicate that the lateral drainage angle approaches a range of 0.5 - 1.5° for an 11% slope, and would be conservative for use with steeper slopes. The assumption was made that the lateral drainage spread reaches a maximum effective width at 1/3 the slope length, and that rill network overlapping occurs beyond that point. This basic effect has been observed, but not measured in the field. With this assumption, the effective drainage widths and areas can be calculated for various slope lengths. This analysis was performed for 3h:1v and 2h:1v slopes and for a 1.0° lateral drainage angle. The corresponding results for allowable slope lengths are illustrated in Tables 2 and 3.

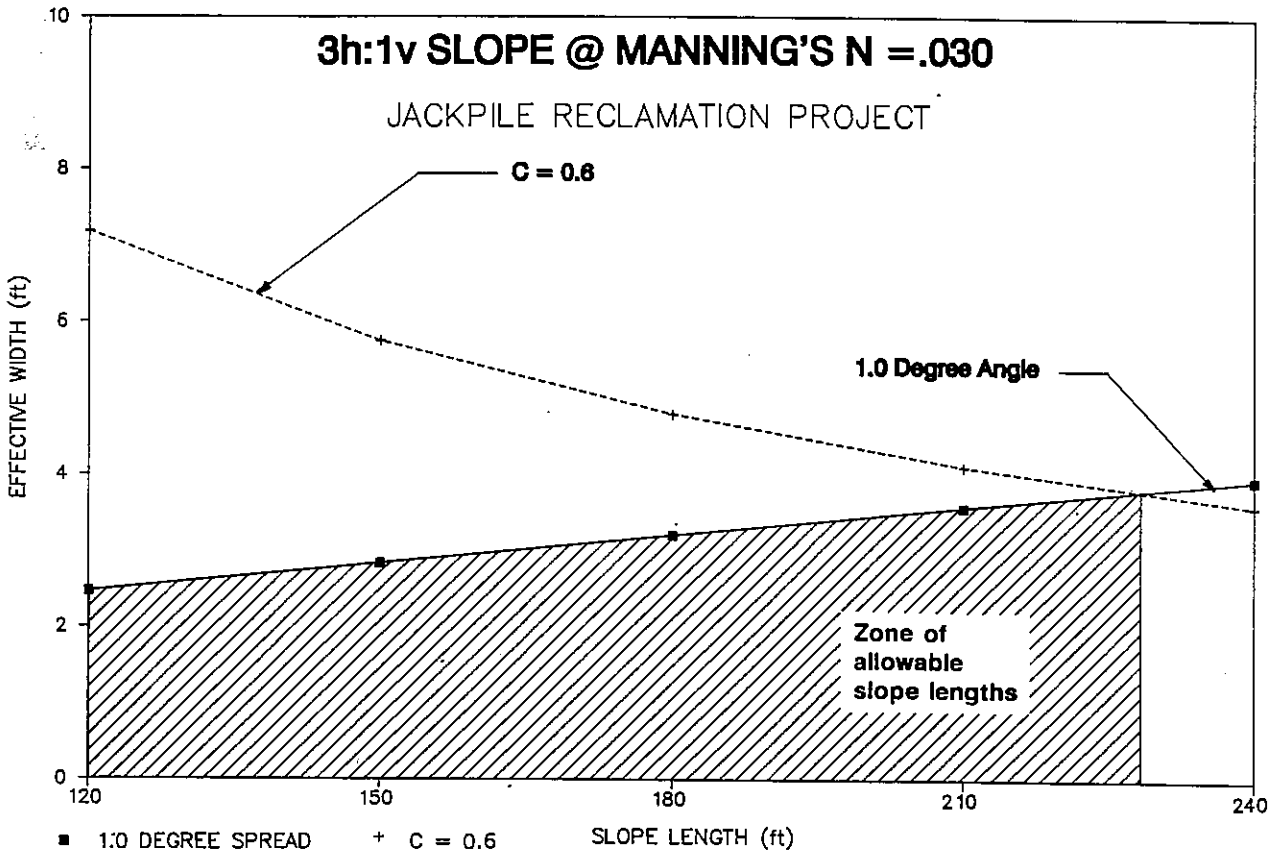

Table 2. Allowable slope lengths, slope 3h:1v.

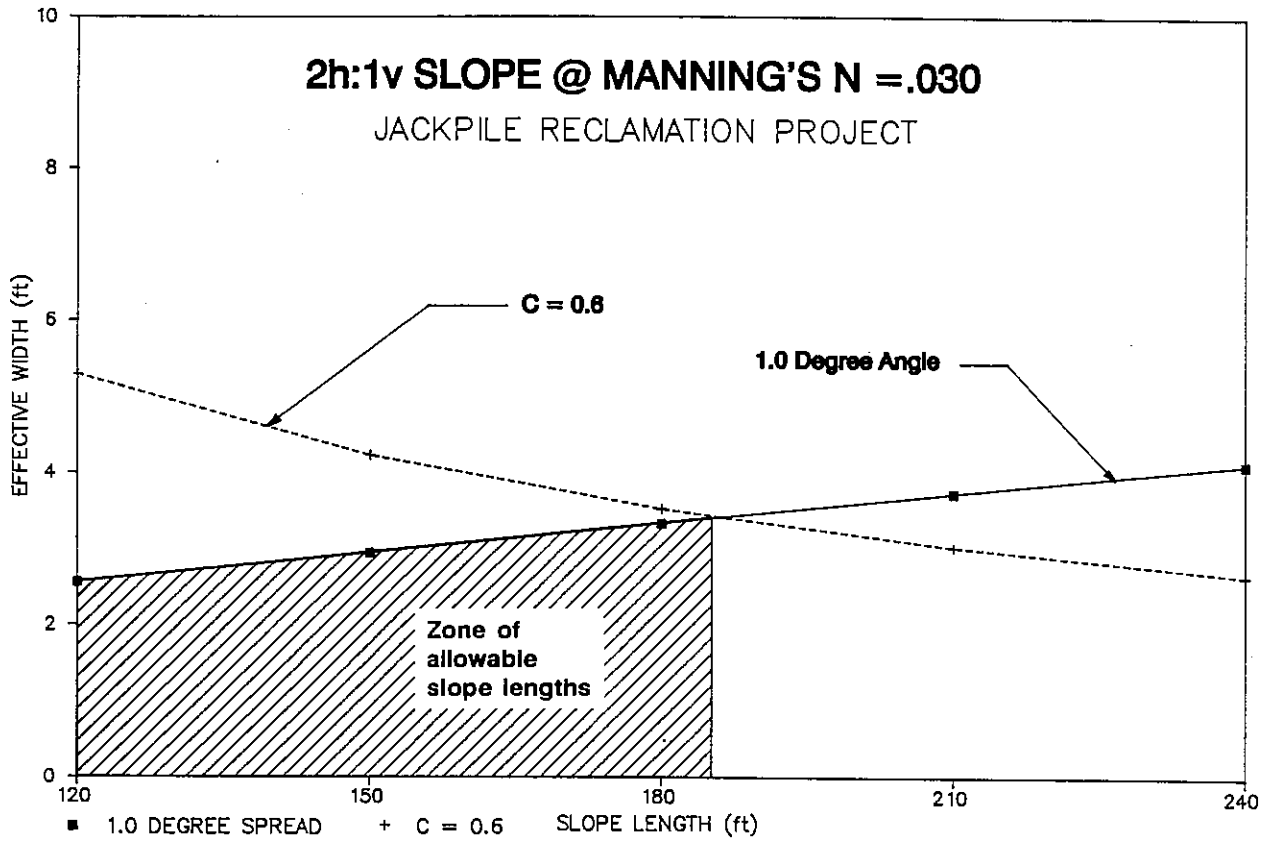

Table 3. Allowable slope lengths, slope 2h:1v.

Final Waste Pile Slope Design

Draining terraces were specified to maintain sufficient geotechnical slope stability. As previously mentioned, the terraces would be retrofit into 3h:1v slopes. Therefore, the most critical point of slope (being the base) would actually be steeper than 3h:1v. For this reason, a 2h:1v slope was also evaluated as shown in Table 3. A typical retrofit terrace is illustrated in Figure 3, using 2h:1v slopes for the cut and fill portions of the terrace. The terrace is also back-sloped at 15% to drain runoff away from the next downward slope segment. The terraces would also be sloped to drain laterally and convey runoff toward level ponding areas or resistant features (high walls and rock outcrops). The terrace lateral slopes will be adjusted, based on terrace length, to maintain flow velocities <3.5 fps with a minimum freeboard of 1 ft.

The allowable slope length of approximately 180 ft was also used as a design criterion to detail a typical terrace

slope. This is illustrated in Figure 4. Each slope segment between terraces or at the top or bottom has an elevation difference of approximately 60 feet. Prevention of contributory drainage from the top of a waste pile is also critical for erosional stability of a steep plane slope.

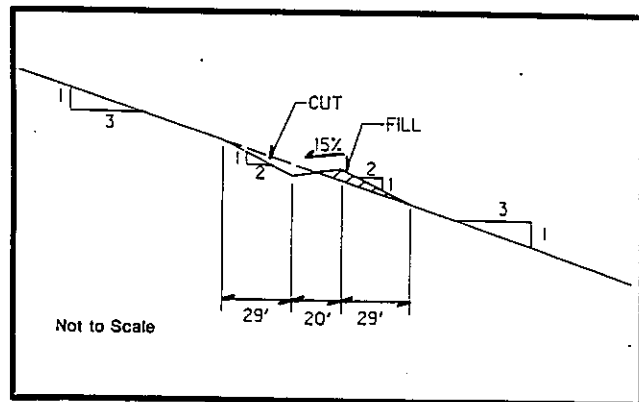

Figure 3. Typical retrofit terrace cross section.

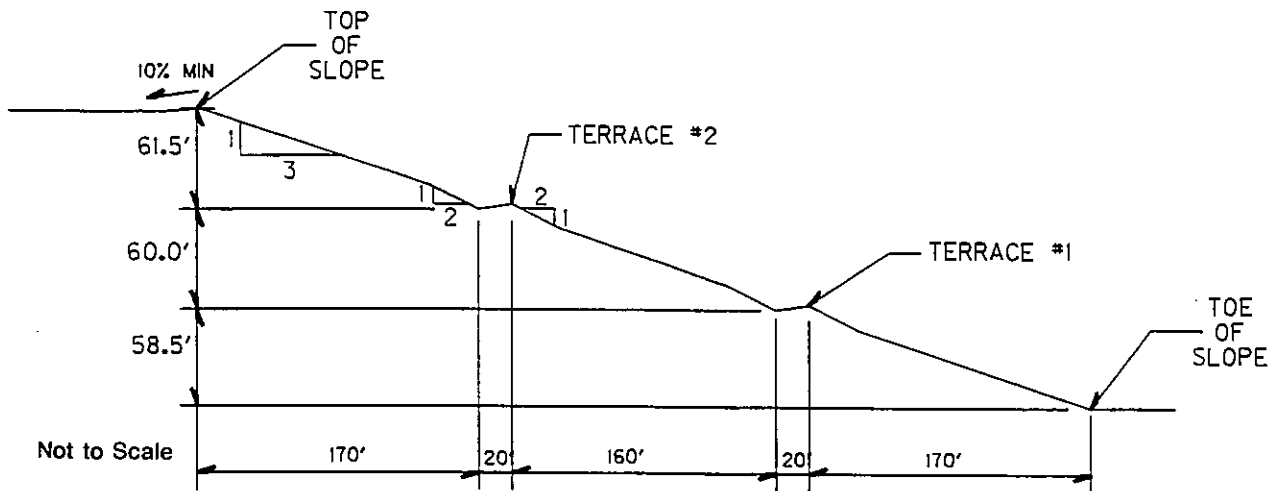

Figure 4. Retrofit 2-Terrace slope.

Literature Cited

AISI. 1971. *Handbook of Steel Drainage & Highway Construction Products*. American Iron and Steel Institute, Washington, D.C.

DOI. 1986a. "Final Jackpile-Paguete Uranium Mine Reclamation Project Environmental Impact Statement." U.S. Department of the Interior, Bureau of Land Management and Bureau of Indian Affairs, Albuquerque, New Mexico. 1986.

DOI. 1986b. "Jackpile-Paguete Uranium Mine Reclamation Project Record of Decision." U.S. Department of the Interior, Bureau of Land Management and Bureau of Indian Affairs, Albuquerque, New Mexico. 1986.

EPA. 1976. "Erosion and Sediment Control, Surface Mining in the Eastern U.S., Planning." U.S. Environmental Protection Agency Technology Transfer Seminar Publication, EPA-625/3-76-006.

Goldman, S.J.; K. Jackson; and T.A. Bursztynsky; 1986. *Erosion and Sediment Control Handbook*. McGraw-Hill, Inc., New York, New York.

Mosley, M.P. 1972. "An Experimental Study of Rill Erosion." Master thesis, Colorado State University, Fort Collins, Colorado.

NOAA. 1973. "Precipitation Frequency Atlas of the Western United States, Volume IV, New Mexico." *NOAA Atlas 2*. U.S. Department of Commerce, National Oceanic and Atmospheric Administration, National Weather Service, Silver Spring, Maryland.

