

SODIUM SILICATE GROUT TECHNOLOGY FOR EFFECTIVE STABILIZATION OF
ABANDONED FLOODED MINES¹

Richard H. Reifsnyder, Robert A. Brennan and John F. Peters²

Abstract -- The construction of support systems to prevent the subsidence of abandoned, flooded mines is difficult and costly. Existing technology, which relies on the placement of fly ash/cement grouts to form supporting columns underwater, is inadequate since the grout quickly becomes diluted by the surrounding water. This results in a separation of the grout components and loss of all self-supporting characteristics of the mix. A new technique has been developed in which the grout stream passes through and reacts with a curtain of sodium silicate during placement to form a calcium silicate gel barrier on the grout surface that limits dilution of the mix by water. A field-scale mine simulation study funded by the Office of Surface Mining, Reclamation and Enforcement has shown that this technique enhances the underwater formation of grout columns with a high angle of repose. Grout columns built using this technique have an average angle of repose 5.5 times greater than control samples and are on the average 48% stronger after 28 days. This process also prevents the separation of grout components and reduces the raw material cost for column construction by a factor of 10.

INTRODUCTION

The subsidence of abandoned coal mines has become an increasingly important problem due to the potential for property damage and loss of life for residents in the affected areas. The stabilization of these sites is of major concern to the Office of Surface Mining, Reclamation and Enforcement and State agencies because the onset of subsidence can be unpredictable and usually requires an immediate and effective response to alleviate the situation. Over the past few years there have been over 50 emergency

subsidence events per year, on the average, involving flooded mines and requiring corrective action. The majority of these events affect only a small area, but if not stabilized quickly and effectively the subsidence can spread, creating hazardous conditions in adjacent areas.

Normally the stabilization of collapsing mines can be remedied easily using the current technology available, but where the site is flooded, this technology can be ineffective and economically unfeasible. The method of mine stabilization currently being used involves the injection of large volumes of a cementitious grout into

¹Paper presented at the 1988 Mine Drainage and Surface Mine Reclamation Conference sponsored by the American Society for Surface Mining and Reclamation and the U.S. Department of the Interior (Bureau of Mines and Office of Surface Mining Reclamation and Enforcement), April 17-22, 1988, Pittsburgh, PA.

²Richard H. Reifsnyder is Technical Service Representative, Robert A. Brennan is Process Engineer, and John F. Peters is Market Development Project Manager, PQ Corporation, Valley Forge, PA.

the mine cavity to partially fill the void and support the weight of the overburden. In most cases the grout mixture used consists of varying proportions of Portland cement and fly ash. Ratios of fly ash to cement range between 5:1 and 9:1 and the ratios are selected based on compressive strength requirements and raw material cost. This grout is injected into the mine via boreholes and usually tremied into place to produce columns or separate piles of grout to support the mine roof. Later the entire void may be filled with a fly ash slurry or mine refuse to complete the stabilization.

Under flooded conditions, this stabilization technique has been found to be ineffective. Building a column that will provide roof contact using a minimum amount of grout requires a low-slump, high-viscosity mixture. When a grout of this type comes in contact with water, the mix starts to become diluted as water passes into the grout matrix. Dilution reduces the viscosity and self supporting properties of the grout, preventing the formation of a column and resulting in a pile exhibiting a low angle of repose. Also, as the grout mix passes through the water, the fly ash and cement components of the grout tend to segregate due to particle size and density differences. Fly ash is separated out of the mix and is washed away or left suspended in the water reducing the volume of the grout that eventually will harden. In many cases, the water within the mine is moving, causing the grout pile to erode before setting is achieved and in some cases actually moving the grout away from the site requiring stabilization.

A new technique has been developed that allows for proper placement of a cementitious grout under water without loss of strength or slump value. This technique relies on passing the grout through a curtain of sodium silicate during placement. On contact, the sodium silicate reacts with the surface of the grout stream, forming a calcium silicate gel that acts as a barrier to prevent water from penetrating into the grout mass and diluting the mix. Silicate also accelerates the set of the grout, allowing it to gain strength quickly and preventing erosion while a column is being formed. Thus, a column is formed using a minimum of material. Previous laboratory work done indicates that grout columns built in this manner display higher angles of repose, faster set times, and higher final compressive strengths than control samples.

In 1987 a series of mine simulation studies were conducted under the guidance of the Office of

Surface Mining, Reclamation and Enforcement in order to evaluate this process under field conditions. In this study, a series of grout columns were built underwater using standard field procedures and equipment and then evaluated for rate of column formation, angle of repose, and final compressive strength. The purpose of this paper is to describe the testing procedures used and the results obtained during this testing.

MATERIALS AND METHODS

Test Apparatus

For this study, a series of 20 ft-diameter by 4 ft-deep swimming pools were erected to serve as the containers for the grout columns to be formed under water. A wide base diameter was needed to allow the formation of the grout piles without encountering containment problems from the walls of the pool. Each pool was filled to 3 1/2 ft with tap water. Above the pools, catwalks were constructed to serve as supports for the grouting pipes and nozzle. This also permitted observers to look down into the pools during grouting to monitor the rate of column growth and grout dispersion. Where roof contact data were taken, a large rectangular platform was suspended from the catwalk just below the surface of the water and secured so that the grout columns could be formed underneath without displacing the platform upward.

The equipment used for mixing and injecting the grout consisted of a 10 ft³, gas-powered mortar mixer; a truck-mounted, gas-powered peristaltic grout pump; a rotary gear pump for silicate supplied from 55 gal drums;

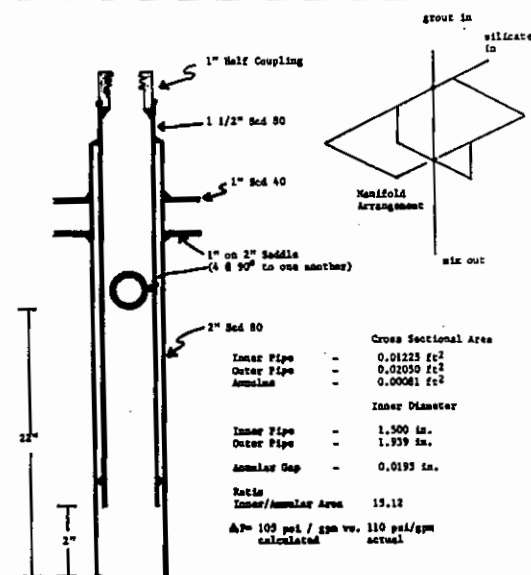

Figure 1. -- Grout nozzle design for silicate delivery.

and an annular nozzle designed to inject the grout mix and silicate simultaneously. The nozzle used was specifically designed to inject a curtain of silicate around the grout stream as it entered the water. Figure 1 details the nozzle design used for these tests.

The grout formulation used for this study consisted of six parts of fly ash to one part cement by volume. The cement used was a Portland type two material and the fly ash a Mercer class F. These components were combined in the grout mixer and tap water was added to bring the total solids of the grout to 72% by weight. The silicate employed was a 3.22:1 weight ratio (SiO₂ to Na₂O) sodium silicate liquid having a solids content of 37.6% by weight. This material is readily available in the United States and may be obtained in drum or bulk quantities.

The testing procedure used was to mix the grout formulation by hand in a batch mixer and feed it as needed to the grout pump, which delivered the mix to the nozzle on a continuous basis. The pumping rates of the grout were calibrated and maintained by tracking displacement in the pool, pump rotation, and the number of batches mixed. The silicate was delivered to the nozzle via a previously calibrated gear pump.

Experimental Parameters

Because these tests were designed to parallel the types of problems that could be encountered in an actual flooded mine, all the experiments were designed to evaluate this system under those conditions. A total of eight tests were conducted. The test parameters are outlined in table 1. In all cases, the angle of repose of the resulting columns formed was used as the key criterion for performance of the system. The calculation for determining average angle of repose is contained in table 1. The total volume of grout pumped in each test was also measured. In most cases, pumping continued until the grout

Table 1. -- Summary of test parameters.

TEST	FLYASH:CEMENT: WATER:SILICATE	FLOW RATE GPM	COMMENTS
1	6:1:3.34:0	8.7	Control
2	6:1:3.34:1.16	8.7	Normal grout with silicate
3	5:1:5:1.24	8.7	Low-solids grout with silicate
4	6:1:3.34:1.12	11.6	Test 2 with increased flow rate
5	6:1:3.34:1.50	11.6	Test 4 with grout tremied in place
6	6:1:3.34:1.16	13.1	Test 5 with column tremied against roof
7	6:1:3.34:1.50	11.6	Test 4 with acidified water
8	6:1:3.34:1.50	11.6	Test 4 with no water in pool

column broke the surface of the water. Visual observations of grout separation and dispersion were also made, by evaluating the clarity of the pool water during grout placement. Water temperature was monitored throughout the testing to determine if it has an effect on column formation or final compressive strength of the solidified grout.

Another variable evaluated was nozzle placement and the method used for constructing the columns. In the early tests, the grout nozzle was located just below the surface of the water causing the grout to free-fall through the water before reaching the pool floor and starting column formation. This type of delivery accelerated the separation of the grout components. For the later tests, the grout was tremied in place by locating the nozzle just above the pool floor and slowly raising it as the column gained height. This technique enhanced column formation and limited grout dispersion.

Once the columns had been formed in the pools, they were allowed to age for 1 or 2 days, after which the pools were drained and the resulting piles were measured and photographed. Sample blocks were cut from each column from the center of the pile. A block 1 ft by 1 ft by 1.5 ft was taken from each and sealed until test samples could be made and evaluated for compressive strength, following ASTM procedures. Strength measurements were taken at 7, 14, and 28 days after column formation for each experiment, and measurements were made in triplicate.

RESULTS AND DISCUSSION

A summary of the operating conditions and results of the eight tests performed during this study are shown in table 2. Table 3 reports the compressive strength results for the samples taken from each grout column and figure 2 displays these results graphically. A short description of each test follows.

The first test run during this study represents a control with no silicate being delivered to the grout nozzle. A grout mix at 72% solids was pumped into the filled pool at a rate of 8.7 gpm. The nozzle was positioned 6 inches below the water surface, and the grout stream fell 3 ft through the water before reaching the bottom to start column formation. The total pumping time was 2 hours and 20 minutes, and a total of 6.2 yd³ of grout was pumped.

Immediately upon starting the pumping the pool water became too

Table 2. -- Summary of operating conditions and results.

Test	Water Temp., Deg. F	Water pH	Nozzle Height, Inches	GROUT Flow Rate, gpm	GROUT Pressure, psig	GROUT Silicate Ratio, By Volume	Silicate Pressure, psig	Volume Pumped, yd ³	Pile Height, Inches	Average Angle of Repose* Deg.	Comments
1	62	8.2	36	8.7	300	0	NA	6.2	18	5	Control, no silicate
2	57	8.2	35	8.7	350	7.9	150	5.7	42	33	Normal grout
3	62	8.3	36	8.7	300	7.9	150	6.2	36	7	Low-solids grout
4	66	11.2	30	11.6	400	9.2	160	6.2	40	53	Higher flow rates
5	51	11.1	12	11.6	350	6.9	195	5.7	43	39	Tremied pile
6	52	10.3	12	13.1	450	7.9	200	6.2	48	45	Tremied against roof
7	55	2.7	12	11.6	450	6.9	200	6.2	42	35	Acid mine test
8	NA	NA	36	11.6	400	6.9	200	3.7	52	36	Pouring pile into air

*Average angle of repose is calculated by taking the arctangent of the following quotient:

$$\frac{\text{Height of the pile from the point it begins to slope upward}}{\text{Diameter of the pile from where it begins to slope upward LESS the diameter of the plateau at the top of the frustum}}$$

Table 3. -- Compressive strength test results.

Test	7 Day	14 Day	28 Day	Test	7 Day	14 Day	28 Day
1	125	175	400	5	250	325	600
	113	200	450		200	400	525
	100	213	375		238	363	550
Mean	112.7	196.0	408.3	Mean	229.3	362.7	558.3
Std Dev.	10.2	15.8	31.2	Std Dev.	21.3	30.6	31.2
2	425	500	625	6	350	500	700
	300	325	675		438	625	725
	375	575	700		413	550	713
Mean	366.7	533.3	666.7	Mean	400.3	558.3	712.7
Std Dev.	51.4	31.2	31.2	Std Dev.	37.0	31.4	10.2
3	213	325	500	7	238	275	750
	225	275	550		188	363	786
	225	350	325		175	325	825
Mean	221.0	316.7	525.0	Mean	200.3	331.0	787.0
Std Dev.	5.7	31.2	20.4	Std Dev.	27.2	36.0	30.6
4	525	650	875	8	225	300	875
	500	700	750		213	338	813
	575	638	900		188	313	838
Mean	533.3	662.7	841.7	Mean	208.7	317.0	842.0
Std Dev.	31.2	26.8	65.6	Std Dev.	15.4	15.8	25.5

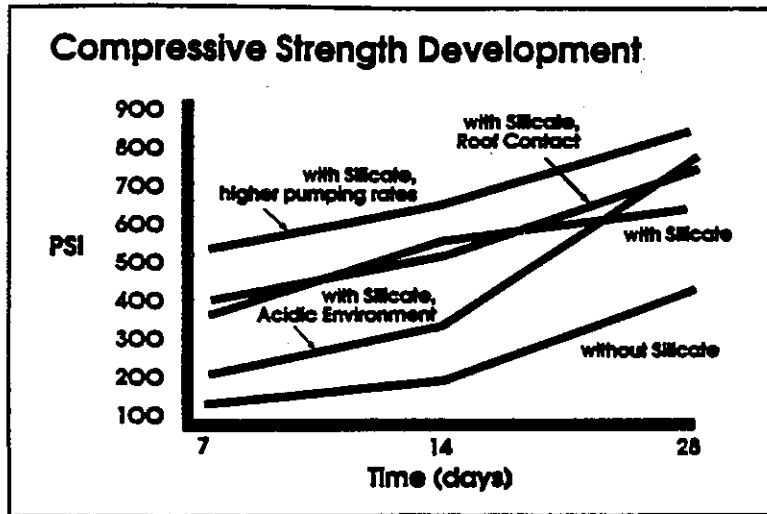

Figure 2. -- Change in compressive strength over time for columns constructed under conditions as shown.

cloudy to see the formation of the pile. This reduction in water clarity indicated that the fly ash from the grout mix was separating out and dispersing. Column formation had to be monitored by probing the grout gently with a pole continually through the test. In this test the grout column never reached the water surface.

After two days, the pool was drained and the pile measured. The column formed was 18 inches high at the center and had an average angle of repose of 5 degrees. The only solidified portion of the column was a small cylinder of grout 2 ft in diameter at the center of the mass. The remaining material was soft and muddy and was of a different color than the rest of the grout indicating that this part of the mass was mainly fly ash that had separated out. The compressive strength of the set portion of the column reached 408 psi in 28 days.

The second test in this series used the same parameters as the first except that silicate was introduced to the grout at the nozzle. One part silicate was pumped through the nozzle for every 7.9 parts of grout by volume. Total pumping time was 2 hours and ten minutes and 5.7 yd of grout were used.

The pool water remained relatively clear throughout the duration of this test, indicating that the grout was not dispersing into the surrounding water. Later examination of the final column verified this. The grout was found to set within minutes after placement, and the column was able to support a man's weight by the time the pumping was completed.

After draining the pool two days later, the grout column was measured and found to have an average angle of repose of 33 degrees. Total height of the column was 40 inches, and the pile was slightly concave on the sides. The entire volume of grout had set, and the final compressive strength was 667 psi after 28 days for this test.

The third test evaluated the effects of silicate on a low-solids grout mix (60% by weight) with an increased cement to fly ash ratio. The proportion of cement to fly ash was increased to enhance the final strength of the set column. A total of 6.2 yd³ of grout was pumped at a rate of 8.7 gpm, and a grout to silicate ratio of 7.9:1 by volume was maintained. A 36-inch-high column with an average angle of repose of 7 degrees resulted. This column never reached the water surface.

The addition of silicate to this grout mix did enhance the viscosity of the grout stream, but did not significantly improve the average angle of repose of the final mass. The final compressive strength was found to be only slightly better than the control sample (525 psi vs 408 psi). Based on these results, it was concluded that silicate had only a marginal benefit for a low-solids grout mix. The remainder of the tests were all run using a 72% solids grout mixture.

For the fourth test, a higher grout flow ratio was used to determine the hydraulic limitations of the grout nozzle. The increase in grout flow rate to 11.6 gpm resulted in a

decrease in grout to silicate ratio. This ratio was 9.2:1 by volume. A total of 6.2 yd³ of grout was pumped, and the test lasted 1 hour and 50 minutes.

There were no adverse effects from decreasing the grout to silicate ratio. The grout mix did not separate as it fell through the water, and the resulting column had an average angle of repose of 53 degrees. The column had a height of 40 inches and was completely solidified throughout the mass. Increasing the grout flow rates seemed to improve the column formation by enhancing the mix of the grout and producing a more uniform mixture. Compressive strength of the column was 842 psi at 28 days.

For the fifth test, 5.7 yd³ of grout was pumped into the pool at a rate of 11.6 gpm. In this test, the grout was tremied in place. The nozzle was lowered into the pool to a height of 12 inches from the bottom, and the column was allowed to grow until the nozzle was buried within the grout. The nozzle was then raised as the pile gained height. Pumping continued until the column broke the surface of the water.

This method permitted a much wider column to be formed. The resulting mass had a height of 51 inches and was 3 ft across at the top. The angle of repose was 39 degrees, and the 28 day compressive strength was 558 psi. The benefits of this method of column construction were very notable. Grout dispersion was strictly curtailed, and the rate of column formation was increased.

The sixth test concentrated on using the previous technique to actually build the column up to a roof and provide a substantial area of contact. A grout flow rate of 13.1 gpm was used, and the test required 6.2 yd³ of material.

The resulting column had an average angle of repose of 45 degrees, and there was a 4-ft-diameter area of roof contact. Contact at the roof was even and level and the platform was well supported along the interface. Final compressive strength at 28 days was 713 psi.

Test seven was conducted in water that had been adjusted to a pH value of 2.7 with sulfuric acid (95%). The standard grout formula was pumped into the pool following the same procedure as test 5. The grout flow rate was 11.6 gpm, and the grout to silicate ratio was 6.9:1 by volume. A total of 6.2 yd³ of grout was pumped during this test.

The reduced pH value of the pool water seemed to have no effect on the

grout mix or the rate and shape of column formation. Column height reached 42 inches, and the average angle of repose was 35 degrees. After 24 hours, the pool water was tested for pH value before draining and was found to have increased to a value of 2.9. This slight increase indicates that the silicate barrier was protecting the grout from deterioration by the acid otherwise the pH value would have increased to a much higher level due to the alkaline nature of the grout components. Final compressive strength was also high (787 psi at 28 days) also indicating that the acid did not affect the grout.

The final test was run in a dry environment following the procedure used in test 2. Grout and silicate were pumped through the nozzle at rates of 11.6 and 1.7 gpm, respectively, and the nozzle was suspended 3 ft from the pool bottom. The nozzle tip was buried within 20 minutes of the start of the experiment and once buried the grout was found to follow the path of least resistance, flowing out of fissures in the growing pile and forming uniformly around the nozzle. The absence of water made observation of the column formation easier.

A total of 3.7 yd³ of grout was used to form a column 52 inches high with an average angle of repose of 36 degrees. Final compressive strength at 28 days was 842 psi.

CONCLUSIONS

The results of the tests performed in this study demonstrate the dramatic effect sodium silicate has on the construction of grout columns in water. During this study we found that the control column, built using 6.2 yd³ of grout without silicate present, attained a height of only 18 inches and had an average angle of repose of 5 degrees. In the other trials, with silicate being introduced at the nozzle, the grout was able to be formed into columns having a high angle of repose, maximizing structure height while minimizing raw material usage. The average angle of repose of the silicate-enhanced columns was at least 5.5 times greater than the control, and all columns achieved a height of 36 inches or more. This is double the height found in the control. The inclusion of silicate into the grouting operation also was found to enhance the stability of fresh grout placed underwater, preventing separation of the grout components while improving its stiffness and self-supporting qualities. In addition, silicate was found to

improve the rate of grout setting and the final compressive strength of the hardened material. All of the factors combine to eliminate most of the problems associated with building support structures in a flooded environment.

Throughout these trials, the average angle of repose of the constructed columns was used as the key criterion of grout performance. Using this measurement, the total volume of grout needed to build a support column of any specific height can be calculated. One problem with using this value is that final column height can significantly affect the average angle of repose measured. Figure 3 shows the final shape of the column built in test 6 and illustrates how the average angle of repose relates to actual column geometry. Columns formed using the silicate/grout process all display this same general configuration. During column construction, a wide base is established at a fairly low angle of repose until the grout mix has gained enough strength to support its own weight. Once the base has stabilized, a column can be built of fresh grout without slippage or collapsing of the structure. Since silicate accelerates the set time of the grout, the amount of material pumped before a stable base is established is reduced. The average base height for the columns constructed with silicate present were 1 ft or less. Since the average angle of repose is calculated using base width and total column height, the concave nature of the structure is not taken into consideration. The greater the height of the column, the greater the discrepancy will be in calculating grout volume needed using average angle of repose.

This type of column configuration was only noted when silicate was used during grouting. In the control test, there was no deviation in actual column geometry from the average angle of repose measured. Without the

benefit of silicate, the mix was unable to form a firm base quickly due to dilution of the grout by the surrounding water. This caused the grout to settle into a low slope pile to achieve stability. There was no concavity noted in this formation.

This difference in column formation is due to the gel barrier formed around the grout stream during pumping. Columns built with silicate all had a thin layer of gel on the outside surface when the pools were drained. The presence of this gel could also be seen inside the columns when they were sectioned to obtain samples for the compressive strength measurements. The formation of this barrier not only limited dilution of the grout by the surrounding water, but prevented the separation of the fly ash and cement components. When using silicate, the pool water remained relatively clear for the duration of the pumping. In the control test, the water immediately became turbid enough so that column formation could not be monitored visually. Examinations of the final columns after the water had been drained also corroborated the fact that the silicate prevented separation of the grout components. In the control test, the column formed was solid only at the center of the grout mass. Fly ash was noted to have settled all along the bottom of the pool in a layer a few inches deep, and the surface of the grout pile was tan indicating that the majority of the material there was fly ash. The columns formed using silicate were found to be uniform in color and in strength throughout the entire mass. There was also an absence of the fly ash layer noted on the pool bottom in the control.

Other than the presence or absence of silicate, no other variable tested had an effect on column slope or angle of repose except for the solids content of the grout mix. In test 3, the solids content of 60% by weight resulted in a very low slump mix (11.75 inches). This grout was sufficiently thin enough to reduce the positive effects of the silicate and resulted in an angle of repose of only 7 degrees for the column formed. Therefore, this mix would not be recommended for field use. Other variables did not affect column geometry: Differences in grout flow rates, grout to silicate ratio, nozzle location, water temperature, or pH value of the water did not contribute to final column shape.

Not only was silicate found to be beneficial in column formation, it also enhanced the ultimate strength of the set grout. Based on a statistical analysis of the data generated, it can

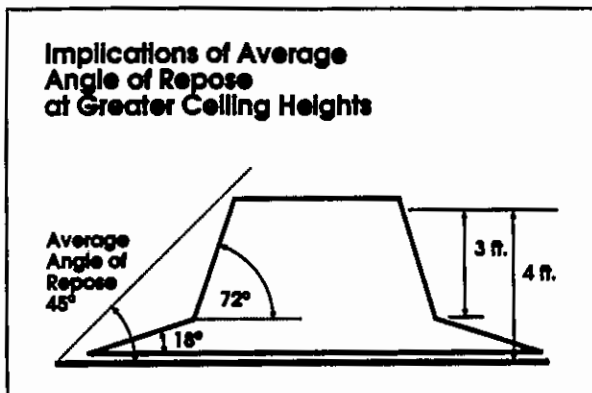

Figure 3. --- Average angle of repose for column 6 as related to actual column geometry.

be inferred, with 90% confidence, that in all tests the silicate improved the final compressive strength of the columns. Based on the data, silicate has the greatest impact on the seven day strengths of the grout. Columns formed with silicate were able to support a man's weight immediately while the control required two days to attain any appreciable amount of load bearing capacity. The benefit of this is that columns formed using this technique would immediately serve to stabilize the mine overburden and limit subsidence.

The flow rates of the grout during pumping did seem to have an effect on column strength. As flow rates increased, the residence time of the grout in the pump and the lines was reduced. This limited the formation of early bonds within the grout that would be broken during pumping and placement. In some cases, these bonds may not be reformed once broken which could theoretically reduce final strengths. More importantly, the higher flow rates improved the mixing of the grout and silicate during placement. Silicate is known to have a positive benefit on the final strengths of cements, and by increasing the amount of silicate incorporated into the column matrix, the resulting strength was improved. This should improve the durability of columns formed in a mine water environment especially since the silicate improves the acid resistance of the grout.

The results of this study indicate that the use of silicate will have a substantial impact on the economics associated with stabilizing a flooded mine. When silicate is used the volume of raw materials needed to support the overburden are significantly reduced. Table 4 outlines the cost for building a 6-ft-high column with and without silicate. For this analysis an average angle of repose taken from the seven tests using silicate is compared with the angle of repose measured for the control column. We assume no concavity for the silicate-formed columns and also include the results from test 3 which reduces the angle of repose value to 27.5 degrees, well

Table 4. -- Raw material costs for column construction.

	CONTROL	AVERAGE OF ALL SILICATE TESTS
Average Angle of Repose	5°	27.5°
Column Height	6 ft	6 ft
Column Base Diameter	243.2 ft	29.1 ft
Column Frustum Diameter	6 ft	6 ft
Column Volume	1244.4 yd ³	61.5 yd ³
Cost of Grout, \$/yd ³	\$32.92	\$63.57
Total Raw Material Cost, \$/Column	\$40,965.65	\$3,909.52

below that measured for all the columns formed using the 72% solids grout mix.

As can be seen from these data, it would take 1244.4 yd³ of grout to obtain a column 6 ft high without using silicate. At a cost of \$32.92/yd³ of grout, it would take almost \$41,000 in raw materials alone to build one support column. With silicate, at an average angle of repose of 27.5 degrees, the volume of grout needed to attain 6 ft in height is reduced to 61.5 yd³. Even with the increased cost associated with including the silicate, the total cost in raw materials is less than \$4,000. Based on this conservative estimate, a silicate-enhanced grout appears to reduce raw material costs by a factor of ten.

Other cost savings should be realized because silicate will reduce the total time and labor costs associated with any one job. By reducing the total volume of grout placed to form a column, the time it takes to complete the stabilization is reduced. Labor costs would then be reduced as well as the equipment rental costs for the total job. Silicate also will allow for columns with adequate roof contact to be built more reliably. This would decrease the need for repeat treatments and should eliminate the loss of raw materials to inadequate columns.

The addition of silicate to the grouting process was found to be simple and required little as far as additional equipment is concerned. The nozzle used for introducing the silicate into the process is relatively straightforward and easy to construct at minimal expense. An additional pump is needed for the silicate delivery, but the cost of this piece of equipment is inconsequential compared to the cost savings realized by using this technology. Specific equipment costs are available from the authors.

SUMMARY

A series of columns were built underwater with and without silicate. The control column formed without silicate had an average angle of repose of 5 degrees and displayed poor compressive strength throughout the structure due to segregation of the grout components. Columns formed when silicate is used in the process were on average 5.5 times greater in angle of repose than the control and were 48% higher in compressive strength. An economic analysis comparing the costs for building a 6-ft-high column with and without silicate shows that the raw material costs alone are reduced by a factor of ten when this technology is used.

ACKNOWLEDGMENTS

The authors would like to acknowledge the assistance and support of the Office of Surface Mining, Reclamation and Enforcement Technical Center East personnel through out this study. Special thanks to Jesse Craft, Jack Holbrook, Tom Crandle, Claude Downing, Bill Morison, and Jim Spotts for their continuing support of this technology.