

TRANSPLANTATION OF GRASSLANDS : I
THE IMPORTANCE OF TRADITIONAL
MANAGEMENT PRACTICES¹

R. Neil Humphries, Philip J. Horton and Paul R. Benyon²

Abstract: Since the 1930's there has been a loss of some 6.7 million hectares of lowland semi-natural grassland in the UK. As a consequence many of the remaining grasslands of nature conservation importance have been given statutory protection. However, planning permission can be granted for developments such as mining, and as a result transplantation may be undertaken as a mitigation measure.

There has been concern and debate about transplantation, because of significant changes in botanical composition and loss of important plant species.

An investigation of a number of transplant schemes in 1991 indicated that the physical conditions, particularly soil wetness, of the donor and receptor sites need to be sufficiently similar to prevent major changes. However, the investigation also indicated that pre- and post-transfer management was a key factor and could be of over-riding importance. It was concluded that traditional grazing and cutting management practices is essential for the maintenance of the nature conservation value of transplanted grasslands.

Additional Key Words: Species Change; Species Composition; Nature Conservation Value

Introduction

Since the 1930s there has been a loss of some 6.7 million hectares of lowland semi-natural grassland in the UK. This has largely occurred through the intensification of agricultural use and changes in policy with respect to food production. Only a proportion of the remaining 200,000 hectares in the mid 1980s was thought to be of conservation importance (Fuller, Barr & Marais, 1986). Many of the remaining grasslands of conservation importance have been given statutory protection as Sites of Special Scientific Interest (SSSIs) under the 1981 Wildlife & Countryside Act (Nature Conservancy Council, 1989). Whilst they have statutory protection against damage and development, planning permission can be granted by local or central government for a variety of other land uses such as mineral extraction provided there is an over-riding case.

Where planning permission has been granted the transplantation of the grassland, as a whole or in part, may be undertaken. Grassland transplantation is the lifting of the vegetation layer and upper soil horizon(s) as an intact turf, and its transportation and relaying of the turves at another location. Transplantation is usually resisted by the statutory conservation agencies who view it as a last resort. However, it is now common for developers, including mineral and mining companies, to include such a proposal as part of their mitigation package.

Over the last fifteen years or so, a number of transplantation schemes involving grassland of SSSI, or potential SSSI, status have taken place. Some examples are listed in Table 1 other examples are given in the two national reviews recently undertaken on behalf of the Nature Conservancy Council (Byrne, 1990) and the British Coal Corporation (Humphries, Horton & Benyon, 1991). Over the last two or three years it appears that transplantation has become much more common, and is now almost a requisite practice where high quality

¹Paper presented at the 1995 National Meeting of the American Society for Surface Mining and Reclamation, Gillette, Wyoming, June 5-8, 1995.

²Humphries Rowell Associates, Prince William Road, Loughborough, Leicestershire, U.K., LE11 0GU.
Proceedings America Society of Mining and Reclamation, 1995 pp 186-193

DOI: 10.21000/JASMR95010186

lowland grasslands are involved.

Naturally, because of reported changes in botanical composition, loss of plant species of conservation importance, and the replacement of communities by less notable ones, there has been concern and considerable debate about the ethical and practical aspects of transplantation (Hopkins, 1988).

Table 1. Examples of grassland transplants in the UK.

Site	Year Started	Reason
Thrislington Plantation	1982	Quarrying of magnesian limestone
Monkspath Meadow	1987	Construction of superstore
Newhall Reservoir	1987	Repair of reservoir
Blackwater Valley	1988	Construction of superstore
Brock's Farm	1988	Extraction of ball clay
Westhay Heath	1988	Extraction of peat
Potatopot	1989	Opencast mining of coal
Brampton Meadows	1991	Widening trunk road
Bleak House	1993	Opencast mining of coal
Selar	1994	Opencast mining of coal

The purpose of this paper is to describe the more commonly reported changes in floristic composition and structure of transferred grassland, and to explain the reasons for the changes and identify the measures necessary to avoid these in future. The basis for our paper is the unpublished review and field survey we undertook in 1991 (Humphries et al, 1991).

Semi-natural Lowland Grasslands of Nature Conservation Importance

The remaining types of semi-natural grasslands in the UK have recently been described and classified as part of the Nature Conservancy Council's National Vegetation Classification (NVC) programme (Rodwell, 1992). There are four principal groups: mesotrophic (MG), calcareous (CG), acidic/upland (U) and fen meadows; the latter being grouped under mire (M) vegetation (Rodwell, 1991). Those grasslands which are of nature conservation importance are recognisable as good examples of their type and which usually contain species of particular conservation interest (Nature Conservancy Council, 1989).

Our investigation (Humphries et al, 1991) indicated that the most likely types of grasslands of nature conservation importance in the UK coalfields are the hay meadow and pasture mesotrophic types. Mesotrophic grasslands are dominated by grasses with associated dicotyledonous herbs, but lack any pronounced calcicole or calcifuge elements. When ungrazed they are conspicuous by the abundance of flowers (Nature Conservancy Council, 1989). Such vegetation is normally found on clay and loam soils of an acid to neutral reaction (pH 5- 7) and generally in lowland situations. Typically mesotrophic grasslands occur in small enclosed field systems used mainly as permanent pasture, but some also as meadows as a source of winter hay feed.

Examples of the mesotrophic (MG) grassland types of importance are listed in Table 2. Of these, the *Cynosaurus cristatus*-*Centaurea nigra* MG5 types are the most likely to be encountered in the coalfields, they are found throughout the UK and on a range of soil types. Their botanical interest "...not only lies in the characteristic species but in the many species of high conservation value to be found in this community" (Nature Conservancy Council, 1989).

Table 2. Mesotrophic grasslands of nature conservation importance.

<i>Anthoxanthum odoratum</i> - <i>Geranium sylvaticum</i> (MG3)
• Northern hay meadow type
<i>Alopecurus pratensis</i> - <i>Sanguisorba officinalis</i> (MG4)
• Southern flood meadow type
<i>Cynosurus cristatus</i> - <i>Centaurea nigra</i> (MG5)
• Dry grassland type
<i>Cynosurus cristatus</i> - <i>Caltha palustris</i> (MG8)
• Typical wet pasture type

Changes Following Transplantation

Four examples have been selected from our national survey (Humphries et al, 1991) to illustrate the most common types of changes induced in pasture/meadow mesotrophic types of grassland following transplantation.

a) Westhay Heath

An extreme example of induced change in grassland vegetation occurred at a peat extraction site called Westhay Heath. The original grassland was described by Buckingham (1988a) as a good example of a species-rich mesotrophic MG5 type hay meadow. A number of local rarities were recorded, including meadow thistle (*Cirsium dissectum*), marsh arrow-grass (*Triglochin palustris*) and quaking grass (*Briza media*). Within two or three years following transfer the vegetation was dominated by reed canary-grass (*Phalaris arundinacea*), reed sweet-grass (*Glyceria maxima*) and tall herb species such as creeping thistle (*Cirsium arvense*). There had been a complete change in grassland type from MG5 hay meadow to MG10 ill drained rush (*Juncus*) pasture/MG13 inundation grassland types (Fig. 1). This rapid change in floristic composition is attributed to the raising of the water on the receptor site to levels higher than those which would normally be associated with mesotrophic MG5 grassland, and to a level associated with MG10/13 types.

b) Monkspath Meadow

Less wholesale changes, but nevertheless significant changes in grassland structure and composition have also been detected even when there is much less marked differences between the donor and receptor sites in soil wetness. The soil profile within the donor site at the Monkspath Meadow super-store site consisted of freely draining sandy loam topsoil over a sandy loam upper subsoil which was probably seasonally waterlogged owing to a red clay horizon impeding drainage at about 0.5m depth. The profile at the Temple Balsall receptor site was subtly different; here the sandy loam/sand subsoil was wet or saturated for a marginally longer period of the year. The meadows at Monkspath Meadow were an extremely species-rich acidic variant of the mesotrophic MG5 type; local species of conservation value included meadow thistle, dyer's greenweed (*Genista tinctoria*) and saw-wort (*Serratula tinctoria*). After some four years the transferred grassland was of a different character at the Temple Balsall receptor site. Structurally the vegetation had become coarser and dominated by the tufted grass, tufted hair-grass, with dominant or abundant rush species (eg. sharp flowered rush (*Juncus acutiflorus*)) and other species of seasonally wet conditions. Many of the constant species recorded in the donor grassland were present, but at a lower frequency (Table 3). Those of local interest, such as meadow thistle, dyer's greenweed and saw-wort were also recorded at a lower frequency (Table 4). The change in structure and frequency of species recorded reflects

the difference in management practice rather than soil wetness; albeit that soil wetness was preventing grazing and cutting of the grassland at the traditional time due to wetter ground conditions (Hill, 1989).

Table 3. Changes in frequency of selected constant species.

Species	Monkspath Meadows -	Potatopot	Newhall
<i>Anthoxanthum odoratum</i>	O	O	
<i>Arrhenatherum elatius</i>			+
<i>Dschampsia cespitosa</i>	+	+	
<i>Cynosurus cristatus</i>	O		
<i>Holcus lanatus</i>	+	O	+
<i>Centaurea nigra</i>	O	O	O
<i>Plantago lanceolata</i>	-		O
<i>Rumex acetosa</i>	+		
<i>Trifolium pratense</i>	-		O
<i>Helictotrichon pubescens</i>			O
<i>Festuca rubra</i>	O	O	O
<i>Dactylis glomerata</i>			O
<i>Briza media</i>			O
<i>Carex flacca</i>			O
<i>Molinia caerulea</i>		-	
<i>Potentilla erecta</i>		O	
<i>Juncus acutiflorus</i>		+	
<i>Agrostis canina</i>		O	
<i>Carex panicea</i>		-	

Key: O = No change + = Increase - = Decline

Table 4. Changes in frequency of species of nature conservation value.

Species	Monkspath Meadow -	Potatopot	Newhall
<i>Cirsium dissectum</i>	-		
<i>Genista tinctoria</i>	-		
<i>Sanguisorba officinalis</i>	O		
<i>Serratula tinctoria</i>	-		
<i>Silaum silaus</i>	-		
<i>Viola hirta</i>			O
<i>Pimpinella major</i>			O
<i>Coeloglossum viride</i>			-
<i>Ophioglossum vulgatum</i>			-
<i>Platanthera bifolia</i>		-	
<i>Polygala serpyllifolia</i>		-	

Key: O = No change + = Increase - = Decline

c) Potatopot

Similar changes in grassland structure and composition have also been detected where there are little or no apparent differences in physical conditions. The transfer undertaken at the Potatopot opencast coal site is understood not to have involved significant changes in physical conditions, including soil wetness. The donor vegetation was a mosaic of essentially grazed fen meadow (M23/M25) and acidic (U) grassland types

(Buckingham, 1987). The fen meadow vegetation was characterised by constant species such as purple moor grass (*Molinia caerulea*), sharp-flowered rush, red fescue (*Festuca rubra*) and tormentil (*Potentilla erecta*), and was species-rich with fifty five species being recorded in 1987. The acidic vegetation type was characterised by the constants red fescue, tormentil, bird's-foot trefoil (*Lotus corniculatus*), sweet vernal grass (*Anthoxanthum odoratum*), common bent (*Agrostis capillaris*) and Yorkshire fog (*Holcus lanatus*). Sixty eight species were recorded in 1987, including a number of notable species such as lesser butterfly orchid (*Platanthera bifolia*), heath spotted orchid (*Dactylorhiza maculata*) and thyme-leaved milkwort (*Polygala serpyllifolia*). Three years after transplantation the vegetation still appeared to resemble that of the donor site, containing the species of conservation value, albeit at a lower frequency, including lesser butterfly orchid (Table 4). However it was evident from quadrat data that there had been an increase in the abundance of tufted hair-grass and rush species with the consequent development of a tussocky structure to the grassland and a decrease in purple moor-grass (Table 3); it is likely that further changes in botanical composition will occur as a result.

The dominance by the grass and rush species, and the development of the tussocky character at Potatopot, is attributed to the withdrawal of grazing before transfer and an inappropriate management regime subsequently.

d) Newhall Reservoir

In contrast with the other examples, significant changes in grassland structure and composition appear not to occur where the grassland is managed up to and following transfer. The grassland at Newhall Reservoir was of the MG5 type with a calcareous element. Prior to the lifting-off and replacement of the grassland on the Victorian reservoir it was described as having fifty nine species; the constant species being hairy oat-grass (*Helictotrichon pubescens*), sheep's fescue (*Festuca ovina*), cock's-foot (*Dactylis glomerata*), quaking grass and glaucous sedge (*Carex flacca*) (Buckingham, 1988b). A number of notable species occurred, including frog-orchid (*Coeloglossum viride*), hairy violet (*Viola hirta*), adder's-tongue fern (*Ophioglossum vulgatum*) and greater burnet (*Sanguisorba officinalis*). Some three and a half years later the constant species from quadrat data still appear to be present. While the dominance of two grasses appears to have increased (Table 3), the grassland composition and structure remains similar to that described in 1987. Whilst some of the species of conservation value, such as hairy violet and greater burnet, are still present, two (adder's-tongue fern and frog orchid) were not recorded in 1991 (Table 4). However failure to record these species is likely to have been due to the lateness of our survey (late June) and is not necessarily indicative of their loss.

Management and the Maintenance of Nature Conservation Value

It is evident from the examples described that both changes in site physical conditions and grassland management can be of significance for the nature conservation value of transplanted grasslands, and mesotrophic grasslands in particular. Clearly, where site conditions are sufficiently different physically, as at Westhay Heath, changes are likely irrespective of the management regime. Where site conditions are not over-riding, as was the case at the other sites, grazing and cutting practices appear to be the key factor in the maintenance of their nature conservation value.

Changes in plant communities and loss of species is not peculiar to transplanted grassland and can occur in undisturbed grassland through changes in the timing and intensity of grazing and/or cutting (Rodwell, 1991 & 1992). The nature of these changes are exactly the same as those recorded for the transplanted grasslands. These include structural changes through dominance by tussocky and coarse vegetation, and changes in composition through the loss and replacement of species.

Typical changes in the mesotrophic (MG) types of grassland induced by particular grazing and cutting regimes are summarised in Fig. 1. It can be seen that winter grazing is of significance in the maintenance of three important grassland types, MG3, MG4 and MG5. Abandonment, summer grazing regimes, or under-grazing can result in changes to other grassland types of less conservation importance. While the model

implies that resumption of the traditional practice can restore the original grassland type, this is dependent on the component species still being present, which may not be the case after a number of years.

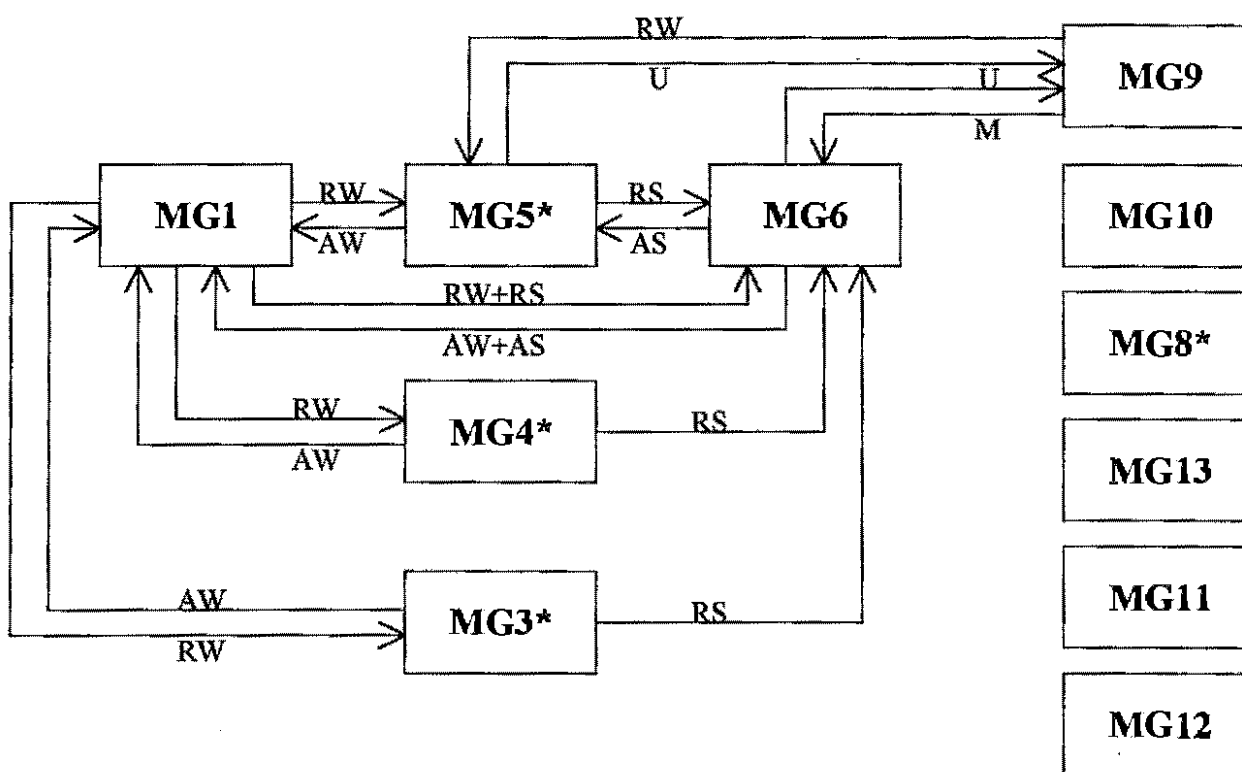

Grassland Types

- MG1 *Arrhenatherum elatius* coarse grassland
- MG3 *Anthoxanthum odoratum* - *Geranium sylvaticum* northern hay meadow type
- MG4 *Alopecurus pratensis* - *Sanguisorba officinalis* southern flood-meadow type
- MG5 *Centaurea nigra* - *Cynosurus cristatus* dry meadow and pasture type
- MG6 *Lolium perenne* - *Cynosurus cristatus* pasture
- MG8 *Cynosurus cristatus* - *Caltha palustris* flood pasture
- MG9 *Holcus lanatus* - *Deschampsia cespitosa* coarse-grassland
- MG10 *Holcus lanatus* - *Juncus effusus* rush pasture
- MG11 *Festuca rubra* - *Agrostis stolonifera* - *Potentilla anserina* inundation grassland
- MG12 *Festuca arundinacea* coarse grassland
- MG13 *Agrostis stolonifera* - *Alopecurus gemiculatus* inundation grassland

Management Regime

- W Winter grazing (August-March)
- S Summer grazing (March-August)
- A Abandonment of grazing
- R Resumption of grazing
- M Mowing
- U Under grazing

* = Those of nature conservation importance

Source: Rodwell (1992)

Figure 1. Grazing and cutting regime induced changes in mesotrophic grasslands.

Hence, it is not surprising that the reinstatement of the traditional grazing and cutting regime is of prime importance in the maintenance of transplanted grasslands. This was demonstrated by the Newhall Reservoir, Monkspath Meadow and Potatopot examples. At Newhall Reservoir there was little change with the resumption of traditional management, in contrast to Monkspath Meadow-Temple Balsall where there were

marked changes following the failure to cut or graze. At Potatopot the grassland was managed inappropriately, here there were still changes in structure and composition, albeit less marked. The latter also suggests that the degree or rate of change may be a function of grazing/cutting regime and intensity, with more significant changes taking place in the absence of management and less significant changes with inappropriate management.

The maintenance of traditional management prior to transplantation is also important as demonstrated by the Newhall Reservoir and Potatopot examples. At Potatopot there had been an increase in dominance of rush (*Juncus spp*) and tufted hair-grass, *Deschampsia cespitosa*) following relaxation of grazing prior to transfer (Anderson et al, 1989). It is not uncommon for significant changes to have taken place prior to transfer, largely through the relaxation or withdrawal of the traditional management practices during the planning process leading up to the development and transplantation. In contrast, the grassland at Newhall Reservoir had been managed prior to transfer and hence no pre-transfer changes were evident.

Lessons to be Learnt

While transplantation will only be successful if the physical conditions of the donor and receptor sites are sufficiently similar to prevent major changes in botanical composition, the key to success is dependent on the traditional management practices being continued up to and following transplantation.

It is clear from our field surveys that the continuation of traditional grazing and cutting management practices up to and following transfer has rarely occurred. Some of the reasons for this and necessary measures are examined in our second paper (Humphries and Benyon, 1995).

Acknowledgements

This work was funded by British Coal Opencast Headquarters. We would like to thank Ian Carolan, British Coal's supervising officer and the staff of English Nature for their help, and the landowners for access to the sites.

References

- Anderson, P. Radford, E. & Dudley K. 1989. Potatopot, Cumbria: Translocation Project. Unpublished report to British Coal Opencast, Northern Region by Penny Anderson Associates, Chinley.
- Buckingham, H. G. 1987. Monitoring Grassland Transplant Sites: Potatopot, Cumbria. Unpublished report by the England Field Unit, Nature Conservancy Council, Peterborough.
- Buckingham, H. G. 1988a. Monitoring Grassland Transplant Sites: Westhay Heath, Somerset. Unpublished report by the England Field Unit, Nature Conservancy Council, Peterborough.
- Buckingham, H. G. 1988b. Monitoring Grassland Transplant Sites: Newhall Reservoir SSSI, Nottinghamshire. Unpublished report by England Field Unit, Nature Conservancy Council, Peterborough.
- Byrne, S. 1990. Habitat Transplantation in England: A Review of the extent and nature of the practice and the techniques employed. English Field Unit Project No. 104. Nature Conservancy Council, Peterborough.
- Fuller, R. M., Barr, C. J. & Marais, M. 1986. CSD Report No. 656: Historical changes in lowland grassland. Nature Conservancy Council, Peterborough.

- Hill, R. 1989. The meadow that was moved: Lessons for the future as the problems emerge. *WARNACT News* 70: 1-2. Warwickshire Nature Conservation Trust, Warwick.
- Hopkins, J. 1988. Habitat transplantation and the safeguard of semi-natural habitat: Draft guidance notes. 14pp. Nature Conservancy Council, Peterborough.
- Horton, P. J. & Benyon, P. R. 1993. Grassland turf transplantation: An assessment of their nature conservation value: 289-291. In Hagger, R. J. & Peel, S. (eds), Occasional Symposium No. 28: Grassland Management and Nature Conservation. British Grassland Society.
- Humphries, R. N. & Benyon, P. R. 1995. Transplantation of Grasslands: II Improvements in field practices and techniques. In proceedings of 12th annual meeting of the American Society for Surface Mining and Reclamation, Gillette, Wyoming, June 5-8, 1995.
<http://dx.doi.org/10.21000/JASMR95010194>
- Humphries, R. N., Horton, P. J. & Benyon, P. R. 1991. Transplanting Semi-natural Grasslands. Unpublished report to British Coal Opencast Headquarters by Humphries Rowell Associates Ltd., Loughborough.
- Nature Conservancy Council 1989. Guidelines for Selection of Biological SSSIs. Nature Conservancy Council, Peterborough.
- Park, D. G. 1989. Relocating magnesian limestone grassland: 264-280. In Buckley, GP (ed) Biological Habitat Reconstruction. Belhaven Press, London.
- Rodwell, J. S. (Ed) 1991. British Plant Communities. Vol 2: Mires & heaths. Cambridge University Press, Cambridge.
- Rodwell, J. S. (Ed) 1992. British Plant Communities. Vol 3: Grassland & montane communities. Cambridge University Press, Cambridge.

