

## RESOLVING ABANDONED MINE CONDITIONS SUSCEPTIBLE TO SURFACE SUBSIDENCE<sup>1</sup>

K. K. Cohen and M. A. Trevits<sup>2</sup>

**Abstract:** Surface subsidence attributable to abandoned underground mines ranks high among abandoned mine land issues. Resolving the conditions that lead to unplanned mine subsidence remains a problem to geotechnical personnel charged with such tasks. A poor understanding of the conditions that lead to subsidence and geotechnical tools with limited subsurface resolving power compound the problem of determining abandoned mine land susceptible to subsidence. Drilling on closely spaced centers is a standard approach to characterizing an area of investigation. Alternative technologies that augment standard procedures have been tested to a limited extent, and are investigated here. Two case studies that represent different stages of subsidence assessment are presented, including an abandoned iron ore mine site in New Jersey investigated with magnetometry and an abandoned anthracite coal mine site in Pennsylvania investigated with seismic techniques. Results from the two case studies demonstrated that the alternative technologies of magnetometry and seismic techniques were valuable in assessing the extent of mining and in identifying different physical conditions within the mine level and overburden. A review of these and other subsidence investigations identified the following tasks as useful in assessing abandoned mine properties: (1) delineating the areal extent of mining, (2) developing models for mine and overburden conditions, (3) conducting field studies with appropriate alternative technologies to target instability zones, and (4) if warranted, implementing a program to monitor mine overburden stability through time. Alternative technologies identified to augment standard drilling practices include geophysical techniques, remote sensing, geochemical surveys, and displacement sensors.

### Introduction

Subsidence, mine fires, slope instability, and acid mine drainage are several issues that are now being addressed in mine land reclamation. Subsidence ranks high on this list of issues and affects abandoned coal, metal, and nonmetal mine lands (National Research Council 1987). Surface subsidence attributed to underground mines results from failure and collapse of mine overburden. When this failure propagates to the surface, it can be manifest as surface disturbances ranging from small potholes or sinkholes (a few meters to tens of meters in diameter, fig. 1) to complex and extensive collapse features such as subsidence troughs. Surface subsidence poses safety risks to residents of communities underlain by abandoned mines, and can damage cultural infrastructure including roads, utilities, and structures.

A wide spectrum of abandoned mine land subsidence research has been conducted to date, and has been directed by Federal, State, and other organizations. This research has focused on such topics as developing subsidence prediction technology (ICF Technology Inc./SRW 1992, Bauer et al. 1991, Walker and Trevits 1990, Munson 1987), underground mine delineation and void detection (Cohen et al. 1992, Friedel et al. 1990, Branham and Steeples 1988), and remediation (Dyini 1993, Burnett et al. 1993). These research topics address issues of subsidence risk assessment, prediction, prevention, and remediation. Few would disagree that, although much progress has been made by this and other research, we are far from answering all the questions that surround these issues. Conditions of the overburden rockmass and at the mine level are ultimately responsible for subsidence; thus, knowledge of these conditions are central to subsidence risk assessment, prediction, prevention, and remediation. Determining mine level and overburden rockmass conditions for

---

<sup>1</sup>Paper presented at the International Land Reclamation and Mine Drainage Conference and the Third International Conference on the Abatement of Acidic Drainage, Pittsburgh, PA, April 24-29, 1994.

<sup>2</sup>K.K. Cohen, Geophysicist and M.A. Trevits, Supervisory Geologist, U.S. Department of the Interior, Bureau of Mines, Pittsburgh, PA, USA.

abandoned mine land susceptible to subsidence is the focus of this paper.

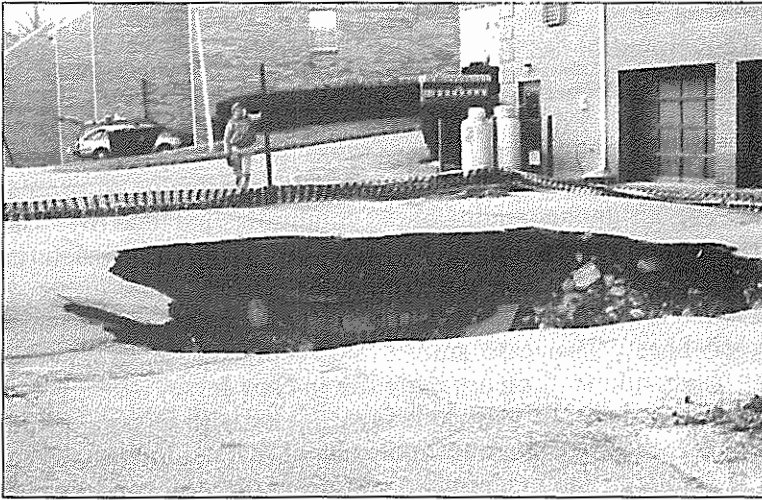

Figure 1. Surface subsidence attributed to collapse above an abandoned underground iron ore mine in northern New Jersey.

conditions prone to subsidence are identified and discussed. In addition, alternative technologies such as geophysical investigations that can augment standard drilling practices (commonly used to assess overburden and mine conditions) are also identified.

### Case Studies

In the following case histories, abandoned mine conditions susceptible to subsidence were investigated through use of field studies. These field studies were selected because they integrated mining and geotechnical information with ancillary geophysical technology.

#### Abandoned Iron Ore Mine

For several decades, a community located in north-central New Jersey has been plagued by subsidence attributable to more than 20 abandoned iron ore mines located under the town. Some of these mining operations predated the Revolutionary War. The mining operations used both open pit and underground mining practices for extraction of the high grade magnetite ore. Mine maps and other geotechnical information are limited and are often over a century old.

Mined property on which a school was built in the 1960's has generated considerable concern. Two subsidence collapse features developed on the property behind the school building in the 1960's. An available mine map for the area was combined with a recent map of the property (Shea and Pustay 1989); the resulting map suggested the subsidence was attributed to slopes used to access the underground workings (fig. 2). Prior to the building of the school, the surface had been graded, and any surface evidence of mining had been destroyed. The two subsidence sites were eventually remediated by excavating down to bedrock, emplacing a 30.5 m (100 ft) long concrete cap over the area, and backfilling to the surface.

This site warrants additional subsidence assessment due to its past history. Numerous boreholes have been drilled, and other geotechnical investigations have been conducted. The boundary of the mining is poorly known and, in part, determined by an historic mine map that is over a century old. Because the limits of the

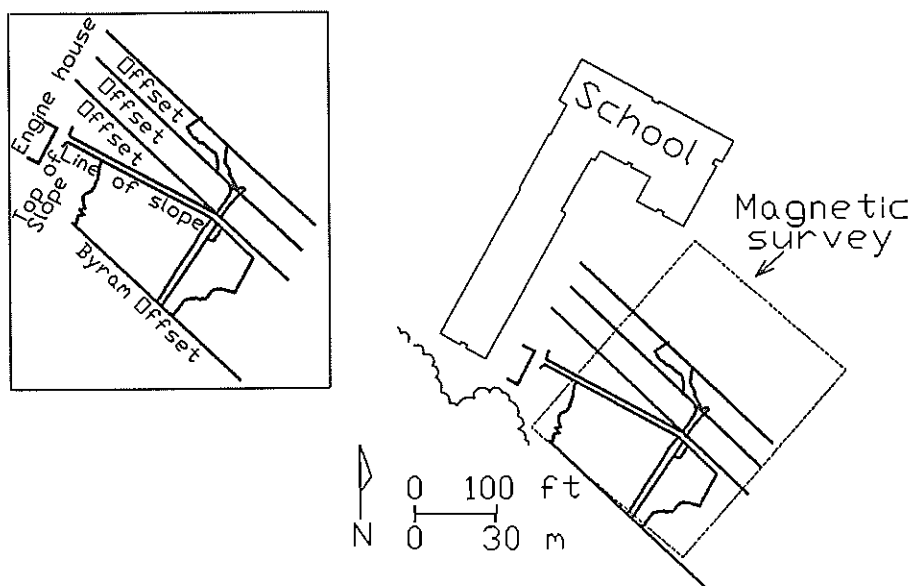

underground mining operations are poorly defined, delineating the areal extent of mining could aid in later targeting specific areas for detailed instability studies.

U.S. Bureau of Mines researchers used magnetometry as a tool to aid in delineating the areal extent of the underground workings (Cohen et al. 1992). This tool was chosen because the ore has an extremely high magnetic susceptibility, a physical property that determines a material's ability to become magnetized. It is proportional to ore grade in this case. The magnetic signature of a magnetic body of known dimensions and magnetic susceptibility can be computed, and extraction of ore from the body should distort this modeled signature. The

Figure 2. Property and mine map of abandoned iron ore mining site in northern New Jersey. Location of magnetic survey indicated on map. Inset shows historic mine map. The magnetic signature (prior to mining) for the ore body at the site was computed, with the necessary model parameters obtained from historic mine records.

A magnetic survey was conducted over the area with a magnetometer using a gridded station array, and these data were contoured (fig. 3A). An anomalous magnetic field pattern was observed, and a profile through the map was compared with a profile for the expected, modeled magnetic field (fig. 3B). The field data confirmed that the site had been substantially undermined. Conclusions drawn from this study were that magnetic surveying of an area confirmed the suspected location of an abandoned iron ore mine; anomalously low magnetic field intensities identified in the survey were attributed to extraction of iron ore. Thus, the extent of mining and areas susceptible to subsidence were delineated. If necessary, more quantitative modeling of these data could be completed to determine the volume of ore removed from the ore body.

### Abandoned Anthracite Coal Mine Site

A town located in the Northern Anthracite Field of eastern Pennsylvania was the site of several subsidence collapse features that developed in 1992. The affected area was an athletic field adjacent to an elementary school (fig. 4A). An old mine map indicated that mining occurred in the earlier part of this century by the room-and-pillar method (fig. 4A). The map suggested that all but four coal pillars had been extracted. The U.S. Office of Surface Mining Reclamation and Enforcement (OSM), Wilkes-Barre, PA, implemented a remediation program for the site. Eleven boreholes were drilled to determine subsurface conditions. These data suggested the mine was in various stages of degradation. In cooperation with OSM, the U.S. Bureau of Mines conducted a geophysical investigation at the site to locate large open voids. The planned remediation program for ground stabilization was to include grout injection through the boreholes. Large, open underground voids were required to effectively inject the grout into the subsurface.

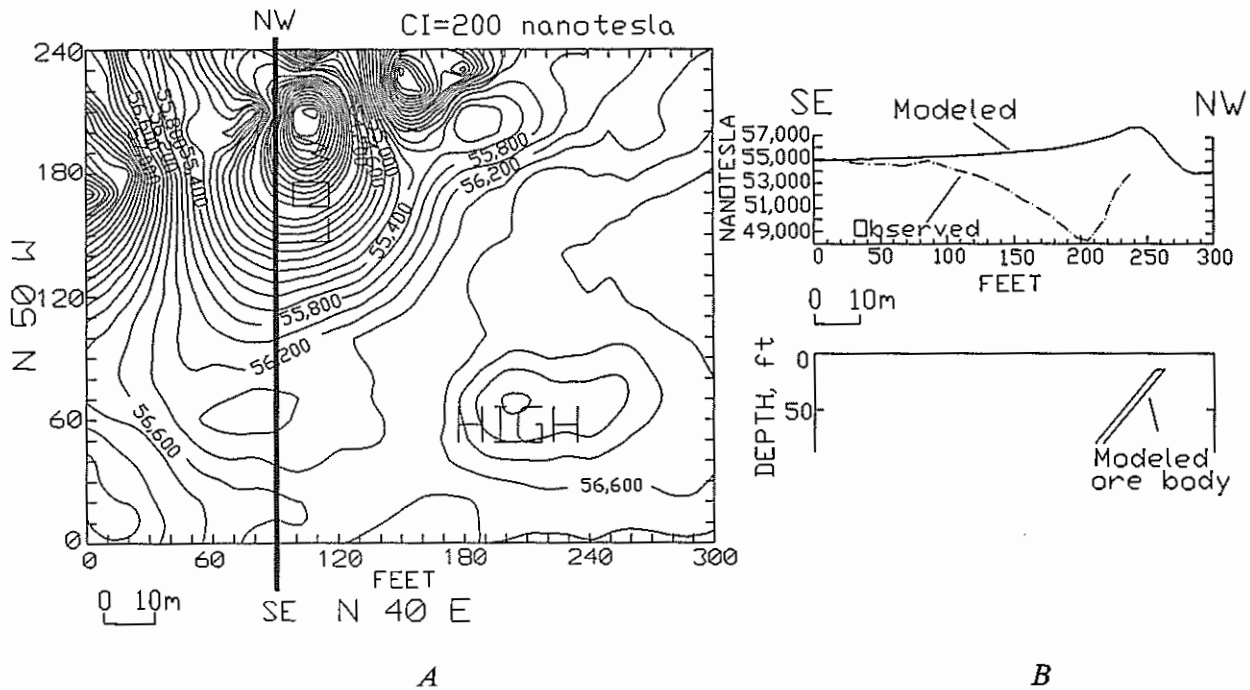
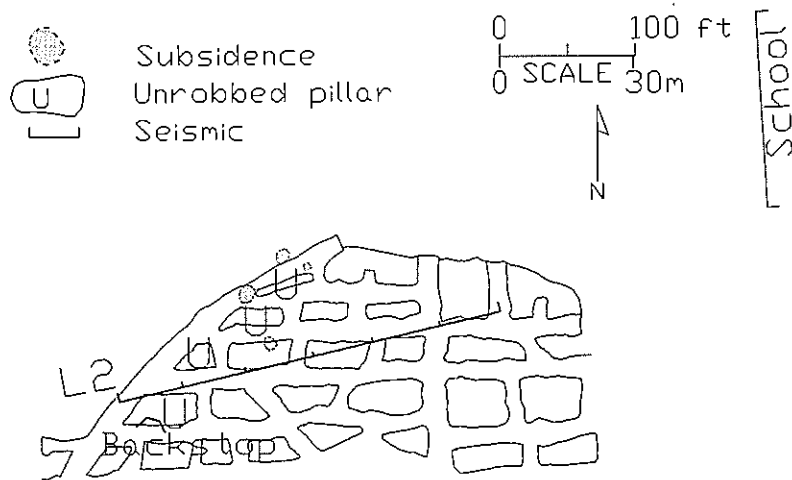

Figure 3. Magnetic field map (A) and observed and modeled profile through map (B).

A seismic method, the optimum common offset technique, was selected for investigation of the site. An engineering seismograph with signal enhancement, 100-Hz geophones, and a sledge hammer energy source were used for data acquisition. A walkaway test was conducted and extended from the unmined zone (as determined from the mine map) into the mined zone; recording parameters as well as shot-receiver offsets varied for this test. Shots were stacked to increase signal-to-noise ratio. Seismic noise, significant arrivals, optimum offset, and optimum recording parameters were identified from the walkaway test. An early coherent, high-amplitude arrival on the seismic record was observed over both the unmined and the mined zone. This was thought to represent the overburden-coal and overburden-open mine void interfaces from the unmined and mined zones, respectively. It was recorded between 40- and 50-ms traveltimes at offset of 36.6 m (120 ft).

Several common offset lines were conducted (using 36.6-m (120 ft) offset) over the area of interest; one of these lines, L2, is provided for the following discussion. In line L2 (figs. 4A and B), only the westernmost portion of the line shows the 40- to 50-ms arrival thought to represent the overburden-coal and overburden-large open void interfaces. This arrival is not observed on the remainder of the record. It is thought that, for the remainder of the record, the mine and overburden conditions are chaotic; along this part of the seismic line it is likely that voids are small and are partly or totally rubble filled. Thus, they do not provide sufficient contrast in physical properties across this boundary and do not effectively return seismic energy to the surface. On this basis, it was decided that two zones existed over the area of investigation (fig. 5): (1) a zone of coal left in place or of large open voids and, (2) a collapsed zone of small voids that are partly or entirely rubble filled. Subsequent to this study, extensive drilling by OSM resulted in more than 20 boreholes and accompanying logs which confirmed these interpretations. Conclusions drawn from this study were that seismic surveying techniques proved effective in characterizing mined property prone to subsidence. Based on the seismic data, two distinct zones were identified at the site, a zone characterized by rubble filled voids and a zone characterized by coal or open voids. Subsequently, borehole data supported these interpretations and provided physical evidence for the presence of the two zones. Subsidence activity at the site indicated that the



A

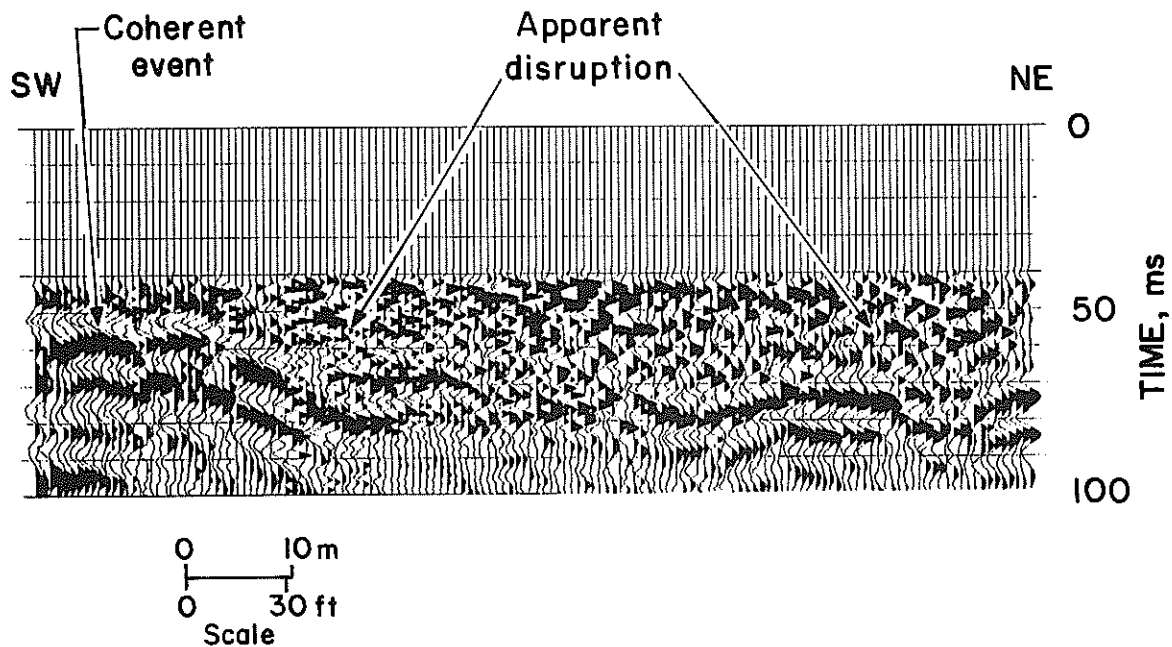

B

Figure 4. Property and mine map of abandoned anthracite mine site in eastern Pennsylvania and seismic results. A, Property and mine map with location of seismic line; B, seismic record from L2.

zone characterized by rubble filled voids was susceptible to ground instability.

#### Assessment of Abandoned Mine Conditions

The cases studies discussed represent two different stages in what could be a sequence of steps designed to resolve mine conditions susceptible to subsidence. From these and other similar studies, steps toward identifying subsidence-prone mine conditions should target the problem area. Tasks that may be necessary or

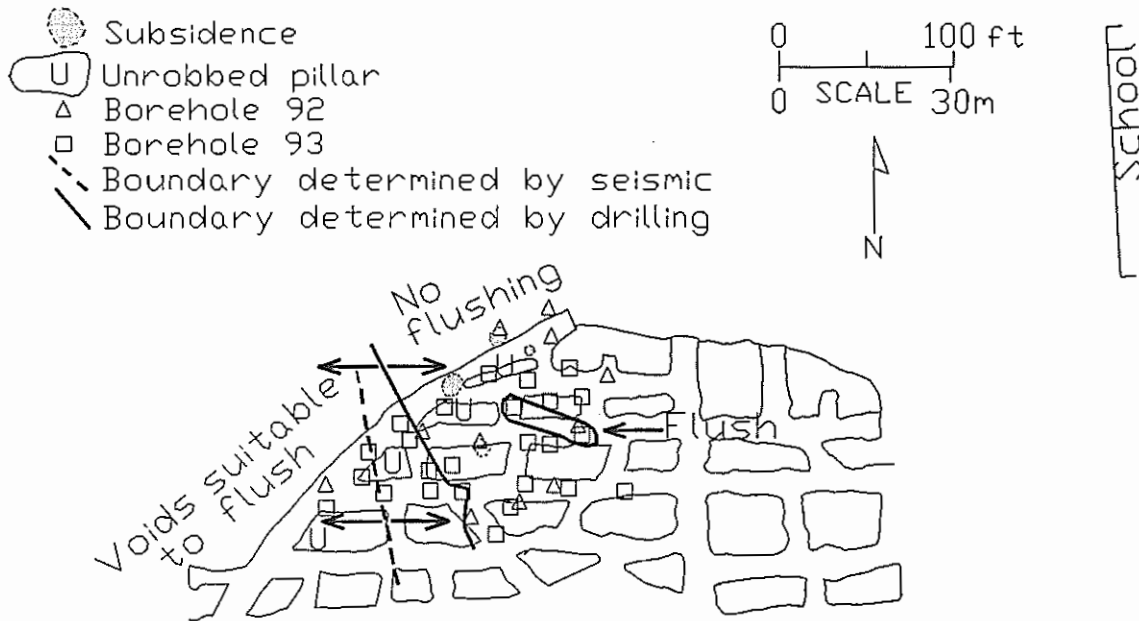

Figure 5. Area shown in figure 4 with the addition of the two zones delineated by seismic and drilling (postseismic) results.

that could prove helpful to accomplish this goal include the following: (1) delineate mined versus unmined areal extent, (2) develop reasonable models and mechanisms for subsidence in the study area, assign physical properties to the mine level and overburden rockmass conditions, and predict physical property changes that occur in these models as instability develops, (3) select appropriate tools to conduct field studies that will resolve these changing properties for the targeted area of interest, and (4) when prediction is required, implement a program to monitor mine overburden stability based on measuring precursory signals of subsidence through time. The goal of these activities is to identify the site prone to subsidence with respect to spatial coordinates and time. Several of these tasks are discussed in more detail in the following.

### Delineating the Extent of Mining

Delineating mined from unmined areas is the first task that must be completed to target a subsidence-prone area if that information is not readily available. Historical mining records in the form of mine and other maps, as well as written and verbal accounts, are of great value and must be obtained when possible. If the area has not been developed, surface remnants of mining may still be observed. Field inspection of these sites can provide valuable information to reconstruct mining conditions. If the area has been developed, such field inspection is most likely of little value.

Even with mining records in hand, it may still be necessary to further delineate the extent of mining from other than historical information. Excavating and drilling are standard procedures used. Valuable information can be provided from these activities because they physically sample the subsurface; however, the information is spatially limited to the excavation or drill hole site. Additionally, these activities can be time consuming and expensive, and cause significant disruption to the ground surface.

Surface geophysical techniques (such as electromagnetics, resistivity, seismic, gravimetry, and magnetometry) and other remote sensing methods provide tools by which large regions can be imaged rapidly and without intrusion (Ackman and Cohen 1994). At sites of investigation, points, lines, and areas can be

surveyed using a variety of geophysical technologies. From these data, models for the subsurface can be derived and, subsequently, a determination can be made as to whether the subsurface is undermined. Numerous case studies exist in the literature in which geophysics was used to aid in delineating mined versus unmined areas (Branham and Steeples 1988, Dobecki 1988, McCann et al. 1987); these are often referred to as "void detection" studies. However, solution sets and subsurface models from geophysical data can be nonunique and often must be verified by some invasive method. Studies should be carried out by personnel experienced in data acquisition, processing, and interpretation. Additionally, cultural development or unique geologic or engineering conditions may preclude the use of some tools listed above.

**The Need for Subsidence Models and Mechanisms**

The areal extent of mining may already be known, or a smaller area within the mined zone may be targeted for further investigation based on past subsidence history or signs of imminent subsidence. What if the task is to resolve unstable mine conditions in the study area? As suggested earlier, the next recommended

tasks are to construct reasonable models of failure for the study area and assign specific physical properties to the mine and overburden conditions. Appropriate field techniques can then be selected for use in identifying failing mine and overburden conditions. These need not be labor-intensive activities, and a specific example follows.

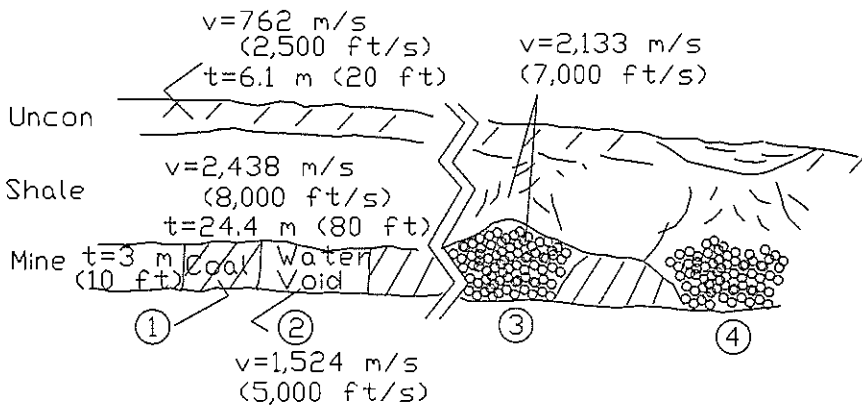
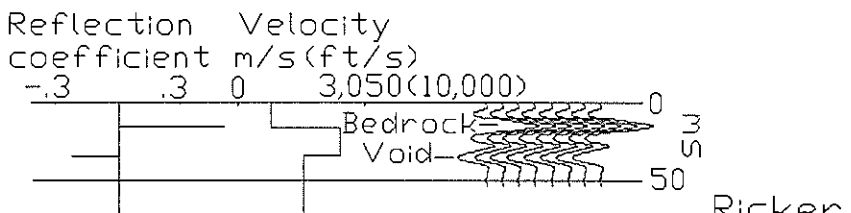

Figure 6. Model for abandoned mine in various stages of degradation.

A



B

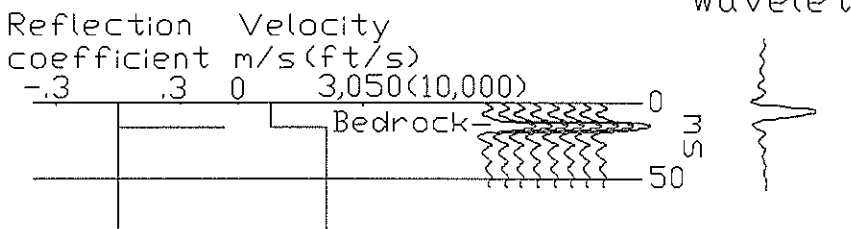

Figure 7. Synthetic seismograms with seismic response for zone 2 (A) and zone 3 (B) in figure 6. Densities not accounted for in these models.

In this hypothetical situation, an abandoned room-and-pillar coal mine is located at depth of 30.5 m (100 ft) (fig. 6). The seam mined is 3 m (10 ft) thick, and the mine is in variable stages of degradation in the model. The mine overburden is composed of a shale interval 24.4 m (80 ft) thick and unconsolidated material 6.1 m (20 ft). Four distinct zones of the mine (fig. 6; 1, 2, 3, and 4) can be characterized with different physical properties, and are discussed here. Seismic velocity was selected as a property to illustrate the utility of modeling. Resultant seismic responses for zones 2 and 3 are presented in figure 7; when compared, the seismic signals are clearly different for each zone. This model suggests that seismic data could provide valuable information

concerning variable subsurface overburden rockmass and mine level conditions. Reports in the literature indicate previous field studies have attempted to determine mine conditions using models and rationale similar to that described above; some have met with limited success (Schwarz 1992, Dobecki 1988).

**Alternative Technologies For Field Investigations**

Alternative technologies to drilling which can be used to investigate subsidence-prone mine conditions are provided in table 1 and include such technology as geophysical techniques and satellite imagery. The suggestion here is not to replace drilling or excavating, but to augment these conventional practices. Identifying appropriate models of failure and consideration of the physical properties of the mine and overburden are tasks critical to resolving subsidence-prone conditions using alternative technologies. With this information, field studies of the area can be completed with the appropriate technology. These tools could have a twofold purpose: (1) to delineate the areal extent of mining and (2) to detect physical property changes in the overburden rockmass that are indicative of instability. As discussed earlier, site-dependent variables will control the selection of tools. Such variables include but are not limited to the following: depth of mining, resource mined, geometry and configuration of mine, condition and physical properties of mine, lithology and physical properties of overburden, topography, hydrologic regime, and cultural interference. These variables determine four controlling factors (McCann et al. 1987) for tool selection: depth of penetration, resolution, signal-to-noise ratio, and contrast in physical properties.

The examples provided previously emphasized geophysical tools, specifically seismic and magnetic techniques. Other nongeophysical tools exist and range from use of remote sensing (aerial or satellite imagery) to geochemical surveys such as soil gas sampling (Trevits and Cohen 1991, Sibley et al. 1988). Table 1 summarizes many of these techniques. The methodologies are divided into geophysical, remote sensing, geochemistry, and displacement sensors. Displacement sensors constitute technology to monitor and detect changes in overburden stability over time; many operate in a "real-time" mode. Field observations such as "Near Surface Indicators" (NSI) are not included here.

**Summary**

A fundamental goal of abandoned mine subsidence investigations is to better target the zone with high risk for subsidence (spatial attributes); assessing mine overburden and mine level conditions is necessary to

Table 1. Alternative technologies with potential to assess subsurface mine conditions prone to subsidence.

---

<p><b>GEOPHYSICAL</b></p> <ul style="list-style-type: none"> <li>Electromagnetic</li> <li>Electrical resistivity</li> <li>Magnetometry</li> <li>Gravimetry</li> <li>Seismic (active surveying)</li> <li>Microseismic/acoustic emissions (passive monitoring)</li> </ul>	<p><b>REMOTE SENSING</b></p> <ul style="list-style-type: none"> <li>Satellite imagery (e.g. visible and near infrared bands)</li> <li>Aerial imagery (e.g. black and white stereo photos, infrared photos)</li> </ul>
<p><b>GEOCHEMISTRY</b></p> <ul style="list-style-type: none"> <li>Soil gas sampling (e.g. carbon dioxide, oxygen, methane, helium, radon, others)</li> </ul>	<p><b>DISPLACEMENT SENSORS</b></p> <ul style="list-style-type: none"> <li>Tiltmeters</li> <li>Time-domain reflectometry</li> <li>Extensometers</li> </ul>

---



complete this goal. Two recent subsidence investigations that used alternative technologies in conjunction with conventional practices to study the sites were presented. These and other studies provide insight into identifying tasks helpful in assessing mine level and overburden conditions. Tasks discussed include: (1) delineating mined versus unmined zones, (2) developing realistic models for mine and overburden failure and assigning physical properties to these conditions for use in the models, (3) identifying tools capable of resolving these physical changes and conducting field investigations with these tools, and (4) when required, implementing a program to monitor mine overburden stability based on measuring precursory signals of subsidence through time. A synopsis of these alternative technologies was provided in table 1.

It is emphasized that drilling and excavating to determine subsurface mine conditions will always comprise an important part in subsidence investigations. Physical sampling of the subsurface cannot be replaced. However, alternative technologies can be used in combination with these standard procedures. In many cases, off-the-shelf technology is currently available to help complete tasks such as delineating the mined zone or determining physical conditions of mine and overburden that could be indicative of instability. Technological advances are on the horizon for many of these tools and will, undoubtedly, increase resolution, depth of penetration, and signal-to-noise ratios. These future advances promise an increased toolbox from which to choose for assessing mine conditions susceptible to subsidence.

#### Acknowledgments

Appreciation is extended to the community of Mine Hill, NJ for cooperation on the subsidence assessment work completed in that area. Cooperation with the U.S. Office of Surface Mining Reclamation and Enforcement (OSM), Wilkes-Barre, PA, enabled the work in the Northern Anthracite Field to be completed.

#### Literature Cited

- Ackman, T.E. and Cohen, K.K. 1994. Geophysical methods: remote techniques applied to mining-related environmental and engineering problems. In press. In Proceedings of the International Land Reclamation and Mine Drainage Conference and the Third International Conference on the Abatement of Acidic Drainage. (Pittsburgh, PA, April 25-29, 1994).  
<http://dx.doi.org/10.21000/JASMR94040208>
- Bauer, R.A., C.H. Dowding, D.J. Van Roosendaal, B.B. Mehnert, M.B. Su, and K. O'Connor. 1991. Final report: application of time domain reflectometry to subsidence monitoring. Final report submitted to Office of Surface Mining Reclamation and Enforcement, Pittsburgh, PA. NTIS No. PB91-228411. 48 p.
- Branham, K.L. and D.W. Steeples. 1988. Cavity detection using high-resolution seismic reflection methods. *Min. Eng.* 40:115-119.
- Burnett, M., R.C. Dyni, and J.M. Burnett. 1993. Field demonstration of two new pneumatic backfilling systems. p. 234-246. In Proceedings of the Conference on Mine Subsidence in Urban and Developed Areas. (Rock Springs, WY, September 9-10, 1993).
- Cohen, K.K., N.N. Moebs, and M.A. Trevits. 1992. Magnetometry as a tool to map subsurface conditions in an abandoned iron ore mining district in New Jersey. p. 91-110. In Proceedings of the Symposium on the Application of Geophysics to Engineering and Environmental Problems. (Oakbrook, IL, April 26-29, 1992).
- Cohen, K.K., P.W. Jeran, M.A. Trevits, and J. Tweedle. 1993. Geophysics ahead of the drill bit for abandoned mine remediation: case study of subsidence remediation in the anthracite fields of Pennsylvania. 1993 Geol. Soc. America Ann. Meeting Abstracts With Programs 25:A-34.

- Dobecki, T.L. 1988. A rapid seismic technique for detecting subsurface voids and unmapped mine workings. p. 666-690. In Proceedings of the Symposium on the Application of Geophysics to Engineering and Environmental Problems. (Golden, CO, March 28-31, 1988).
- Dyni, R.C. 1993. An instrumented pneumatic backfilling system. BuMines RI 9485, 14 p.
- Friedel, M., J.A. Jessop, R.E. Thill, and D.L. Veith. 1990. Electromagnetic investigation of abandoned mines in the Galena, KS, Area. BuMines RI 9393, 20 p.
- ICF Technology Inc./SRW. 1992. Design and implementation of a monitoring system to detect imminent subsidence in the anthracite region of northeastern Pennsylvania. U.S. BuMines Contract Report J0178024. 204 p.
- McCann, D.M., P.D. Jackson, and M.G. Culshaw. 1987. The use of geophysical surveying methods in the detection of natural cavities and mineshafts. Quart. J. Eng. Geol. 20:59-73.  
<http://dx.doi.org/10.1144/GSL.QJEG.1987.020.01.06>
- Munson, R.D. 1987. Subsidence monitoring using seismic activity. DOI-OSMRE/BOM Contract Report J5160064. 69 p.
- National Research Council. 1987. Setting priorities for abandoned mine land research. National Academy Press, Washington, DC. 98 p.
- Shea, T.K. and M.R. Pustay. 1989. Abandoned mines of Mine Hill, Randolph Township and Wharton Boro, Morris County, NJ. NJ Dept. of Labor. 101 p.
- Sibley, R.D. and P. Grainger. 1988. Soil gas geochemistry: A potential method for detecting old mine workings. p. 61-67. In M.C. Forde (ed.), Mineworkings 88: Proceedings of the 2nd International Conference on Construction in Areas of Abandoned Mine Workings. Engineering Technics Press, London.
- Schwarz, S.D. 1992. Detection of distressed rock and potential collapse features above old mine workings by the seismic refraction method. p. 281-287. S.H. Ward (ed.), In Geotechnical and environmental geophysics, vol. III: Geotechnical, Society of Exploration Geophysicists, Tulsa, OK.
- Trevits, M.A. and K.K. Cohen. 1991. Could radon gas anomalies signal impending subsidence of abandoned mine lands? Abstract presented at the 13th Annual Abandoned Mined Land Conference, Oct. 7-10, 1991, Lake of the Ozarks, MO.
- Walker, J.S. and M.A. Trevits. 1990. Development of an early warning system for detection of subsidence over abandoned coal mines. p. 41-49. In Proceedings of the AEG Subsidence Symposium.