

# REHABILITATING MINE TAILINGS WATER USING CONSTRUCTED WETLANDS

by

Aisling D. O'Sullivan, Declan A. Murray and Marinus L. Otte

**Abstract.** Outokumpu Zinc-Tara Mines Ireland, located approximately 50 km north of Dublin, is Europe's largest producer of lead and zinc ores. Water used during extraction and purification of these ores is enriched with sulfate and heavy metals. Presently, this water together with suspended tailings, is pumped from the mine and stored in a large tailings settling pond. Two experimental artificial wetlands were built beside this settling pond to treat seepage. The primary strategy employed for treatment of the water is the reduction of sulfate to sulfide. The wetlands are maintained anaerobic to provide optimum conditions conducive to reduction reactions. This process is mediated by sulfate reducing bacteria, which are indigenous in the bedding substrate (spent mushroom compost) used. The alkaline nature of the mine tailings water (due to the strong buffering capacity of the prevailing limestone geology) facilitates the subsequent precipitation of metal sulfide complexes which form following reduction of sulfate. The constructed wetlands have been in operation for two years but have exhibited consistent removal of sulfate from water. Recent results suggest that algae, having spontaneously invaded the wetland ecosystems, also play a substantial role in the removal of heavy metals from the tailings water. To-date, this decontamination approach is showing to be efficacious and cost-effective.

Additional Key Words: treatment wetlands, sulfate, algae, heavy metals.

## Introduction

Water quality of run-off and leachate from metalliferous mine tailings is generally not compliant with national (Irish Government, Water Pollution Amendment Act 1990) or international standards. It is characteristically high in heavy metal and sulfate concentrations resulting from ore processing. Maximum reported levels in process water at Outokumpu Zinc-Tara Mines Ireland are 0.22 mg L<sup>-1</sup> lead, 2.58 mg L<sup>-1</sup> zinc and 3016 mg L<sup>-1</sup> sulfate (Tara Mines 1995). Practices for rehabilitating wet mine tailings have more recently favored the use of wetlands for water treatment and for revegetation of sediment tailings (McCabe and Otte *In Press*).

Wetlands have the ability to immobilize heavy metals and similar pollutants, consequently removing contaminants from wastewater (Hammer 1989, Gambrell 1994). Such a technique, exploiting this filtering property of wetlands, is currently being employed on an experimental scale at Outokumpu Zinc-Tara Mines Ireland. Two constructed wetlands were built and have now been in operation for over 2 years, in an attempt to demonstrate their potential use, practicality and cost-effectiveness for treating wastewater at a large scale.

Removal of pollutants from wastewater and subsequent retention of precipitated compounds in wetlands is somewhat accommodated by their physical properties (Dvorak *et al.* 1992), but chemical and biological processes are of more significance (Roane *et al.* 1996). Wetlands are regularly flooded, usually contain emergent vegetation and their substrates are generally anaerobic. Under these conditions, microorganisms, which are indigenous in the bedding substrate (spent mushroom compost) used in the constructed wetlands at Tara Mines, can reduce sulfate to sulfide. These sulfate-reducing bacteria (*Desulfovibrio spp.*)

<sup>1</sup>Paper presented at the 2000 National Meeting of the American Society for Surface Mining and Reclamation, Tampa, Florida, June 11 - 15, 2000.

<sup>2</sup>Aisling O'Sullivan is Research Assistant, Declan Murray is Senior Lecturer of Zoology and Marinus Otte is Lecturer of Botany, National University of Ireland at Dublin (UCD), Belfield, Dublin 4, Ireland.

Proceedings American Society of Mining and Reclamation, 2000 pp 438-445

DOI: 10.21000/JASMR00010438

respire using sulfate (instead of oxygen) as electron acceptors for their metabolism (Tate 1995). The resulting sulfide is subsequently precipitated as metal sulfide complexes. Aquatic macrophytes are commonly recommended for use in treatment wetlands for a variety of reasons (Kadlec 1996). Additionally, algae are reported to remove heavy metals and similar substances from mine-polluted waters (Wildeman and Laudon 1989). Algal mats and macrophytes provide suitable habitats for bacterial colonization. Considerable quantities of heavy metals can also be adsorbed onto cell surfaces and accumulated by plants (Boyd 1978). More recently, periphyton has been considered a bio-eliminator in its ability to retain heavy metals and other elements in artificial wetlands (Sladeckova and Matulova 1998).

### Materials and Methods

#### Design and Experimental set-up

Two experimental wetlands, each comprising three compartments in series, were constructed at the site of the tailings facility of Outokumpu Zinc-Tara Mines Ireland in August 1997. Both systems receive different qualities of tailings water. System 1 is supplied with seepage water collected from an interceptor ditch surrounding a large settling pond. System 2 receives run-off from an inactive tailings dam on site, but can be complimented with supply from system 1 should supply of run-off be low. The first compartment, an 'inflow' pond, receives untreated tailings water, which overflows into a vegetated 'wetland' section, which in turn overflows into an 'outflow' pond (Figure 1). The waterproof baffles in the wetland sections increase the flow passage of water, thereby increasing the capacity for bioremediation in a limited space. A computer on site is permanently connected to pumps to regulate flow of tailings water. Connected to the same computer are four industrial-grade electrodes (Rosemount Solu Cube<sup>®</sup> Analyzer Model 2700), one in each of the four ponds. These facilitate continuous monitoring of conductivity and temperature. Data are logged into a database (every six hours) which can be accessed remotely via a portable modem. This assists monitoring the performance of the systems from our laboratory, 50-km distance, at the Belfield campus of University College Dublin using pcANYWHERE 32™ software.

Pilot experiments conducted during early 1997 indicated that a combination of optimum plant growth and suitable substrate permeability was achieved in a medium containing Spent Mushroom Compost [SMC] (25 %) and fine grit (75 %). Each wetland compartment

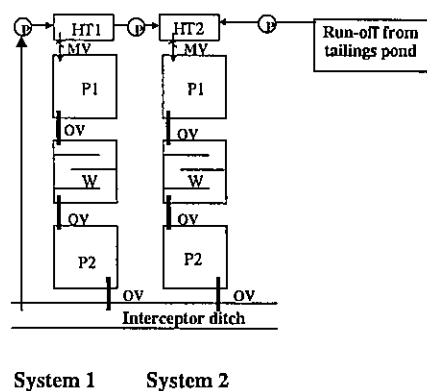

Figure 1. Design of the experimental set-up at the Randalstown tailings facility of Outokumpu Zinc - Tara Mines Ltd. near Navan, Co. Meath. Two separate systems, each comprising a pond receiving untreated tailings water, a wetland compartment and a pond containing treated (i.e. after passage through the wetland compartment) water. All three compartments in each system measure about 4 m x 4 m x 2 m (L x W x D). HT = header tank, MV = manual valve, P1 = ponds receiving untreated tailings water, W = wetland compartments, P2 = ponds receiving treated water, OV = overflow. One system receives water pumped from the interceptor ditch (System 1), while the System 2 receives run-off from a vegetated tailings pond. During periods of low supply of run-off, both systems receive interceptor ditch water.

was filled with ca. 50-cm depth of this mixture. Mushroom compost is also regarded as one of the best organic substrates for sulfate reducing microorganisms (Ledin and Pederson 1996). Furthermore, it is commonly accepted that SMC is a suitable substrate employed in the treatment of tailings water using wetlands (Stark and Williams 1994). At the base of the other four ponds in each system, a 1:6 mixture of Spent Mushroom Compost (ca. 50-cm depth) and fine grit was deposited in order to provide a substrate for spontaneous invaders of the systems. Planting density was based on similar research on constructed wetlands (Szczepanska and Szczepanska 1982, Kadlec and Alvord 1989). *Typha latifolia* (4 plants per m<sup>2</sup>) and *Phragmites australis* (9 plants per m<sup>2</sup>) were planted in the wetland compartments of each system during August 1997. *Glyceria fluitans* (7 plants per m<sup>2</sup>) were added in August 1998. Presently, flow rates have been fixed at approximately 400 mL min<sup>-1</sup>. These rates were based on values given for other operational systems as described by Crites (1994) and adapted to fit the size of the experimental wetlands. The theoretical residence time for the systems is 52 days, but the actual retention time has yet to be confirmed.

### Field Survey

The site is visited on a monthly basis and monitoring of many different parameters occurs. Here we are reporting on sulfate trends to date and the role of algae in bio-filtration of heavy metals within the systems. Conductivity and temperature were measured using the industrial electrodes mentioned above. Redox potential was measured using a platinum electrode connected to a mV meter (WTW pH90). For analysis of sulfate, a Dionex ion chromatograph was used. Samples of algal material (10 X 10 cm<sup>2</sup>) were taken from randomly selected locations within the four inflow and outflow ponds. Material was dried at 80 °C for 5 days and then analyzed for iron, lead and zinc concentrations by Flame Atomic Absorption Spectrophotometry (Pye Unicam) following acid-digestion in Teflon bombs as described in Beining and Otte (1996). Water samples were filtered through a 0.45 µm filter and then analyzed using the same spectrophotometer. Algal samples were washed (in distilled water) to investigate potential variability in concentrations from surface deposits. These samples were compared with unwashed samples, but no differences were detected. Therefore, unwashed samples were used for metal analyses.

### Statistical Analyses

Data on concentrations are typically log-normally distributed (Sokal & Rohlf 1981), therefore all concentration values were log-transformed prior to statistical analysis to obtain homogeneity of variance. Paired t-tests were performed to detect differences between washed and unwashed algal samples. One-way Analysis of Variance (ANOVA) was carried out to test for significant differences in metal content.

## Results

### Sulfate reduction

Data obtained beginning 9 months following completion of the systems are presented (Figure 2). However, only data following the 12-month period are discussed in this paper. This is because the wetlands required an initial settling and equilibration phase once they had been flooded, and planting had not been completed until August 1998. Performance of the experimental wetlands over the later fourteen months period (October 1998-November 1999 inclusive) was promising. Removal of sulfate from the tailings water having passed through the systems was consistent. Observations of sulfate removal are presented here as trends, which indicate percentage differences between concentrations in the inflow and outflow ponds (Figure 2). Percentage reductions range from 0% to 48 % but

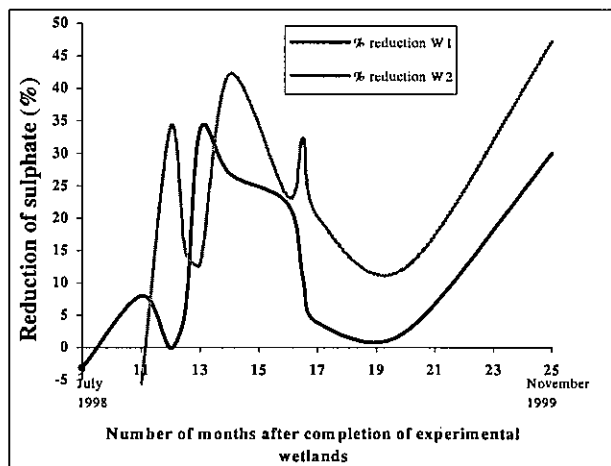

Figure 2. Average percentage reduction (calculated as a percentage of inflow minus outflow concentration) in sulfate concentrations (mg L<sup>-1</sup>) between inflow (P1) and outflow (P2) (Fig. 1) of both experimental systems W1 and W2. Values represent means and are presented for the period July 1998 to November 1999. Number of measurements is five. Average concentration values and standard deviations range between 281±27 mg L<sup>-1</sup> (minimum) and 942±30 mg L<sup>-1</sup> (maximum).

generally exceeded 15%. Wetland 2 showed larger removal of sulfates than system 1 after the initial 13 months period. Greater reductions in sulfate concentrations occurred during the winter periods at the 14 months (December 1998) and 25 months (November 1999) sampling dates. Results of redox potential, calculated over the sampling period, indicated differences in seasonality. Values in the winter months, showed greater reduced soil environments in both experimental systems compared with summer months (Table 1).

Table 1. Average values ± standard deviations of redox potential Eh (mV) of the substrate (wetland compartments), measured at 20 - 25cm of both experimental systems. Number of measurements is five. Average monthly, surface water temperature data recorded in the systems are also given, expressed in °C.

System	Season (1998-1999)			
	Winter		Spring-Summer	
	Dec 98	Feb 99	March 99	June 99
Temperature	4	8	11	16
1	-314±68	-439±82	-224±18	-129±18
2	-444±55	-569±27	-150±8	-114±21

### Algae as bio-eliminators

Apart from plants purposely planted in the wetlands (*Phragmites*, *Typha* and *Glyceria*) a number of other species voluntarily colonized the experimental wetlands (*Ranunculus tripartitus*, *Calliargon cuspidatum*). Algae (Table 2) invaded both systems within a year and by 15 months after completion (February 1999), the inflow and outflow compartments of both systems were approximately 50% covered with filamentous floating algae. The exception to this was the inflow in system 2, in which no such algae have appeared to-date. As can be seen from Table 2, different species colonized various compartments of the experimental systems. Comparisons between locations for metal concentrations in algae were somewhat confounded as a result. Nonetheless, interesting trends emerged. No detectable differences were evident between elemental composition (Zn, Pb) of washed and unwashed sub-samples of algae. Paired t-tests confirmed that both sets of results were statistically similar with  $P > 0.05$  for the vast majority of tests performed individually for each element in each compartment. Therefore all concentrations presented here are for unwashed algal samples.

Water concentrations for zinc ranged from  $0.12 \mu\text{mol L}^{-1}$  (inflow, system 1) to  $30.6 \mu\text{mol L}^{-1}$  (inflow, system 2), (Table 3). Analysis of metal concentrations in the algae indicated that they may contribute significantly to removing heavy metals from the tailings water. On observation of Tables 3 and 4, it is clear that a greater fraction of zinc and lead are

Table 2. Algal species recorded and their occurrence in the experimental systems between the sampling period October 1998 to March 1999.

Identification		Occurrence	
Species (Family)	System	Compartment(s)	
<i>Chara</i> sp. (Charophyceae)	1	Inflow	
<i>Microspora</i> sp. (Chlorophyceae Ulotrichales)	1	Outflow	
<i>Cladophora glomerata</i> (Chlorophyceae Oedogoniales)	1	Inflow, Wetland, Outflow	
	2	Wetland, Outflow	

Table 3. Averages  $\pm$  standard deviations of heavy metal concentrations ( $\mu\text{mol L}^{-1}$ ) for zinc and lead in surface water, sampled for the winter period (December 1998-February 1999). Number of measurements is fifteen.

	Zinc		Lead	
	System			
	1	2	1	2
Inflow	$0.12 \pm 0.02$	$30.56 \pm 1.32$	*	$0.08 \pm 0.03$
Wetland	$0.33 \pm 0.27$	$12.46 \pm 8.43$	$0.06 \pm 0.02$	$0.06 \pm 0.06$
Outflow	$0.14 \pm 0.10$	$0.60 \pm 0.18$	*	*

\*Denotes below the detectable limit

associated with the algae compared to water. A preliminary study carried out in December 1998 indicated consistent reduction of metal concentrations measured in algae from outflow ponds relative to inflow ponds (Rafferty 1999). This trend was also seen for zinc concentrations in water in system 2. A second analysis for metals in algae was undertaken in samples collected at the end of January 1999. Results are presented in Table 4. A large degree of variation was detected between replicates. In order to confirm this variability, some samples were analysed repeatedly. Values recorded for the twice-tested samples were generally consistent with the first analysis. Reductions in iron (97%) and zinc (92%) concentrations between the wetland compartments and outflow ponds for algae were greater in system 2 than in system 1. In fact, in system 1, zinc was not retained within the wetland, exhibiting an outflow concentration greater (by 50%) than the inflow. Similarly, zinc levels in the water showed a 95% reduction between wetland and outflow compartments of system 2, but like for algae, levels were greater in the outflow of system 1 compared to the wetland by 17% (Table 3). Lead values for water were below the detectable limit in both outflow compartments, so comparisons cannot be made. However for algae in system 2, figures were over 50% less in the wetland compartment compared to the outflow. The opposite trend was seen for system 1 for the same element. Differences between inflow and outflow compartments in system 1, for algal sampling dates (December 1998, January 1999), were all found to be significant at the 95% confidence level (Rafferty 1999). Furthermore, differences in their concentrations as a function of (wetland/outflow) location for systems 1 and 2 were significant at this level with the exception

of lead. Similar statistical analyses were conducted on zinc concentrations in water in all compartments of the experimental wetlands and differences ( $P < 0.001$ ) were detected between all locations for system 2 (Rafferty 1999).

### Discussion

#### Sulfate reduction

Sulfate removal from both experimental wetlands was consistent over the period documented here. These observations confirmed earlier findings (sampled when the systems were between 11 and 13 months) indicating significant differences for system 1 between inflow and outflow at the  $P < 0.001$  level (O'Sullivan *et al.* 1999). Conductivity of water samples, a measure of the total ionic strength of the water, was positively correlated with sulfate concentrations measured in the experimental wetlands at the same time period (O'Sullivan *et al.* 1999). Due to the relatively mild Atlantic climate prevailing in Ireland, winter temperatures do not reach sub-zero for any period of time (greater than a week). The annual range of temperatures recorded in the experimental wetlands at Tara Mines did not fluctuate greatly (Table 1), and hence microbial activity in winter was probably not reduced considerably by comparison to summer activity. Counter to other studies published, larger reductions in sulfate concentrations were exhibited during the winter periods. This may be attributed to the die-back of the vegetation during this season, by comparison to the spring/summer periods when vegetation growth was prolific. *Typha latifolia* is known to exude oxygen from its roots and rhizomes, hence oxygenating the rhizosphere (Dunbabin *et al.* 1988). Since the strategy for removing sulfate in the experimental wetlands at Tara Mines involves the reduction of sulfate to sulfide under anaerobic soil conditions, oxygenating by rhizomes of *Typha latifolia* and other plant species could possibly limit this reduction reaction. Furthermore, an increase in organic matter returned to the rhizosphere during the autumn/winter die-back period can result in a corresponding increase in microbial biomass and bacterial activity (Karjalainen *et al.* *In Press*). These authors found a positive correlation between sulfatase enzyme activity and organic matter, suggesting a greater potential for removal of nitrate from the water. Permanently oxygen deficient soils are a pre-requisite for facilitating reduction reactions. The reduced plant activity and increased organic matter in the wetlands therefore, may perhaps explain the greater percentage removal of sulfate during the winter period. Redox

Table 4. Averages  $\pm$  standard deviations of heavy metal concentrations ( $\mu\text{ mol g}^{-1}$ ) for unwashed algae sampled in January 1999. Species of algae analysed correspond to the compartment where they occurred as detailed in Table 2. Percentage reductions in metal concentrations are also shown. Number of measurements is five.

System	(Location)	Element		
		Iron	Lead	Zinc
1	Inflow	33 $\pm$ 30	0.22 $\pm$ 0.12	7.9 $\pm$ 4.5
	Wetland	39 $\pm$ 20	0.09 $\pm$ 0.10	7.7 $\pm$ 3.3
	Outflow	8.8 $\pm$ 10	0.09 $\pm$ 0.04	17.8 $\pm$ 7.7
<b>Reduction (%)</b>				
	Inflow-Outflow	<b>73.3</b>	<b>59.1</b>	<b>-55.6</b>
	Wetland-Outflow	<b>77.4</b>	<b>0</b>	<b>-56.7</b>
2	Inflow	*	*	*
	Wetland	108 $\pm$ 116	0.13 $\pm$ 0.10	25 $\pm$ 14
	Outflow	3.1 $\pm$ 1.6	0.20 $\pm$ 0.03	2.0 $\pm$ 0.6
<b>Reduction (%)</b>				
	Wetland-Outflow	<b>97.0</b>	<b>-54.0</b>	<b>92.0</b>

\*Denotes no algal colonization occurred in this location

potential values, which are a measure of the redox status of the substrate, appear to concur with these observations. However, some oxygen entering the rhizosphere enables plants to counteract effects of phytotoxins, including sulfides and metals, in the water in which they grow (Gambrell and Patrick 1978). This is accomplished through precipitation of metals close to the root surfaces, and may be explained by the oxidation of iron and manganese to hydrous oxides, which have a high surface area and adsorptive capacity for metals and phosphorus. The complete sulfur and metal budgeting of these experimental systems is currently being elucidated through the measurement of sulfate and metal concentrations in all the (sub-) compartments. Additionally, sulfides in pore water, total sulfur in plants and acid-volatile sulfide in sediments are being quantified and will be reported elsewhere.

### Algae as bio-eliminators

Interpretation of the results of algal metal analysis are confounded to some extent due to variation in the species, density, precise location and depth at which the algae were sampled. Since different species colonized different compartments of the wetland systems, comparison between the same species could not be applied. Different species of algae, growing under similar environmental conditions, may contain different levels of elements (Boyd 1978). Selective accumulation or exclusion of an element is characteristic of the individual species and therefore only marginally influenced by external concentrations (Kelly 1988). Furthermore, algal mats were not of uniform thickness and hence were growing to unequal depths in the water. It is possible that elemental content of these samples varied with distance from the surface. It is also likely that algae, which grew to deeper depths, had a greater surface area exposed for potential exchange of elements. This view is supported by Horner *et al.* (1990), who noted that diffusion of nutrients and penetration of light into algal mats might be limited by their thickness. Morphological and physiological aspects of algae, in addition to the chemical and physical conditions in the immediate environment, may account for some of the observed differences.

The reason why filamentous algae failed to colonize the inflow pond of system 2 can only be speculated upon. Toxicity tests carried out on *Cladophora glomerata*, indicated that a 50% reduction in specific growth occurred at zinc and lead concentrations of  $1.1 \mu\text{mol L}^{-1}$  and  $5.0 \mu\text{mol L}^{-1}$  respectively (Kelly 1988). The lead recorded in the inflow pond of system 2 was far below this specified level, but the zinc concentration was greater by a magnitude of 30. Chances of colonization in the inflow pond of system 2 therefore, at least by this algal species, were evidently reduced due to the elevated zinc levels prevailing.

An assumption of this research is that metal concentrations found in algal tissue are positively correlated with concentrations in the medium. Other studies, documenting nutrient and metal uptake, found uptake concentrations significantly proportional to applied external concentrations (Khan and Khan 1983). We hypothesized that metal concentrations in algae in the outflow ponds would be lower than in inflow compartments. This hypothesis was based on two assumptions (1) that water would contain lower levels of metals in outflow ponds, having been filtered by the wetland compartments, and (2) uptake by algae was proportional to ambient water metal concentrations. Algae appear to concentrate high levels of metals in

their tissues, indicative of sequestration. This is apparent from the greater fraction of zinc and lead measured in algae compared with water (Tables 3 and 4). Significant reductions in iron, lead and zinc levels in algae were detected in outflow ponds compared with inflow ponds for system 1 (data not shown). Differences in zinc and iron algal concentrations, between wetland and outflow compartments, also indicated significance for both experimental systems (Rafferty 1999). Concurrently, zinc levels in water for all 3 compartments of system 2 were found to be statistically significant. However, these significant findings were presented in an undergraduate thesis and are open to interpretation. The sampling was conducted twice only and we feel therefore that results are not conclusive to-date. The most apparent difference between systems was the greater concentration of zinc in outflow pond of system 1 after having passed through the wetland. This was seen in both algae and water concentrations, but was only significant for algae (data not shown). The same trend was obvious for lead levels in system 2, to the same degree (Table 4), but this too was not shown to be significant. The reasons for this behavior are not clear. Due to the nature of the mining industry, concentrations in supplies entering the wetlands varied depending on ore output, so the experimental wetlands were subjected to varying loads of elements in the tailings water. Clearly, species of algae and degree of exposure to metals, are important variables instrumental in determining metal concentrations in algae, and require further investigation. The sampling described here was conducted during the winter, and in order to confirm definitive observations, further seasonal sampling will be incorporated into the monitoring procedure. Future research will aim to quantify and correlate sulfate and metal removal, specifically by the algae that have colonized the treatment wetlands. These results, although preliminary, suggest that the algae, which colonized the experimental wetlands, have the ability to concentrate relatively high levels of heavy metals from the external medium. This observation indicated the potential of filamentous algae to function as bio-eliminators in wastewater treatment. At present, the complete budgeting for sulfur and metal elements is being quantified by measuring levels in water, plants and sediments concurrently to observe sediment driven processes and seasonal effects.

### Conclusions

Despite some complexity in the observations, this study indicates that algae can contribute to retention of metals (iron, zinc, and lead) and possibly

sulfates in treatment wetlands. The colonization of such filamentous algal mats is regarded as beneficial for ecological diversity too, since algae attract certain invertebrate species (Marshall Darley 1982). In the first 16 months since completion of these experimental wetlands, 33 species of invertebrates have been identified. Results emerging from this research to-date are promising, indicating that wetlands can be used to effectively reduce heavy metal and sulfate concentrations in mine tailings water. Removal of these substances is achieved through a complex array of chemical and biological reactions, employing plants, algae and microorganisms in the sediments.

### Acknowledgements

This research is supported by Outokumpu Zinc-Tara Mines, Ireland and an Enterprise Ireland Applied Research Grant (HE/1997/205). Thanks to Ms Maeve Rafferty for carrying out the metal analysis of algae.

### Literature Cited

Beining, B.A. and Otte M.L. (1996). Retention of metals originating from an abandoned lead-zinc mine by a wetland at Glendalough, Co. Wicklow. *Biology and Environment: Proceedings of the Royal Irish Academy* 96B: 117 - 126.

Boyd, C.E. (1978). Chemical composition of wetland plants. *In: Freshwater Wetlands: Ecological Processes and Management Potential* (Ed. Good, R.E., Whigham, D.F. and Simpson, R.L.). Academic Press, London.

Crites, R.W. (1994). Design criteria and practice constructed wetlands. *Water, Science & Technology* 29(4): 1-6.

Dunbabin, J.S., Pokorny, J and Bowmer, K.H. (1988). Rhizosphere oxidation by *Typha dominigensis* Pers. in miniature artificial wetland filters used for metal removal from wastewater. *Aquatic Botany* 29: 303-317.

Dvorak, D.H., Hedin, R.S., Edenborn, H.M. and McIntire, P.M. (1992). Treatment of metal-contaminated water using bacterial sulfate reduction: results of pilot-scale reactors. *Biotechnology and Bioengineering* 40: 609-616.

Gambrell, R.P. (1994). Trace and toxic metals in wetlands —a review. *Journal of environmental Quality* 23: 883-891.

Gambrell, R.P. and Patrick Jr, W.H. (1978). Chemical and microbial properties of anaerobic soils and sediments. *In: Plant Life in Anaerobic Environments* (Ed. Hook, D.D. and Crawford, R.M.), pp. 375-423. Ann Arbor Science, Ann Arbor, Mich., USA.

Hammer, Donald A. (1989). *Constructed wetlands for wastewater treatment: municipal, industrial and agricultural*. Lewis Publishers, Chelsea, Mich., USA.

Horner, R.R., Welch, E.B., Seeley, M.R. and Jacoby, J.M. (1990). Responses of periphyton to changes in current velocity, suspended sediment and phosphorus concentration. *Freshwater Biology* 24: 215-232.

Irish Government (Department of Environment) (1990). *Water Pollution Amendment Act and Implementation of the 1989 Surface Water Regulations, L17/89/SWR*, Government Publications, Dublin, Ireland.

Kadlec, R.H. (1996). Wetland design: surface flow wetlands: Plants and Planting. *In: Treatment Wetlands* (Ed. Kadlec, R.H. and Knight, R.L.) pp.633-634. Lewis Publishers, CRC Press, Florida.

Kadlec, R.H. and Alvord, H. (1989). Mechanisms of water quality improvement in wetland treatment systems. *In: Wetlands: Concerns and Successes* (Ed. D.W. Fisk), pp. 489-498. American Water Resources Association, Florida.

Karjalainen, H., Stefansdottir, G., Tuominen, L. and Kaireslo, T. (*In press*). Do submersed plants enhance microbial activities in sediment through root metabolism? *Verh. Internat. Verein. Limnol.*

Kelly, M. (1988). *Mining and the Freshwater Environment*. Elsevier Applied Science, London.

Khan, S. and Khan, N. (1983). Influence of lead and cadmium on the growth and nutrient concentration of tomato (*Lycopersicum esculentum*) and egg-plant (*Solanum melongena*). *Plant and Soil* 74: 387-394.

Ledin, M. and Pederson, K. (1996). The environmental impact of mine wastes-roles of micro-organisms and their significance in treatment of mine wastes. *Earth Science Reviews* 41(1-2): 67-108.

Marshall Darley, W. (1982). *Algal Biology: A Physiological Approach*. Blackwell Scientific Publications, Oxford.

- McCabe and Otte (*In press*). The wetland grass *Glyceria fluitans* for revegetation of mine tailings. *Wetlands*.
- O'Sullivan, A.D., McCabe, O.M., Murray, D.A. and Otte, M.L. (1999). Wetlands for rehabilitation of metal mine wastes. *Biology and Environment: Proceedings of the Royal Irish Academy* 99(B): 11-17.
- Rafferty, M. (1999). Fauna and algae in an artificial wetland treating mine tailings water. Unpublished B.Sc. thesis, University College Dublin, Ireland.
- Roane, T.M., Pepper, I.L., Miller, R.M. (1996). Microbial remediation of metals. *In: Bioremediation, Principles and Applications* (Ed. Crawford, R.L. and Crawford, D.L.), pp. 312-340. Cambridge University Press, Cambridge.
- Sladveckova, A. and Matulova, D. (1998). Periphyton as bioeliminator. *Verh. Internat. Verein. Limnol.* 26(4):1777-1780.
- Sokal, R.R. and Rohlf, F.J. (1981). *Biometry*. 2nd Ed. W.H. Freeman & Co., San Francisco.
- Stark, L. and Williams, F. (1994). The roles of spent mushroom substrate for the mitigation of coal mine drainage. *Proceedings from Spent Mushroom Substrate Symposium*, pp 74-85, March 11-14, 1994, Philadelphia, PA., USA. The JC Press, Emmaus, PA., USA.
- Szczepanska, W. and Szczepanska, A. (1982). Interactions between *Phragmites australis* (Cav) Trin. ex Steud. and *Typha latifolia* L.. *Ekologia Polska* 30(1-2): 1165-1186.
- Tara Mines Limited (1995). *Environmental Impact Statement*, Tara Mines Publications, Navan, Ireland.
- Tate, R.L. (1995). The sulfur and related biogeochemical cycles. *In: Soil Microbiology* (Ed. Wiley), pp. 359-381. New York.
- Wildeman, T.R. and Laudon, L.S. (1989). Use of wetlands for treatment of environmental problems in mining: non-coal mining applications. *In: Constructed wetlands for wastewater treatment: municipal, industrial and agricultural*, (Ed. Hammer, D.A.) pp. 221-226. Lewis Publishers, Chelsea, Mich., USA.