

TESTS OF ORGANIC MATTER ADDITIONS
FOR THE
NEUTRALIZATION OF ACID MINE DRAINAGE INFLUENCED LAKES¹

by

Richard B. Brugam, James Gastineau, and Eric Ratcliff²

Abstract. Many investigators have proposed that dissimulatory sulfate reduction by anaerobic bacteria should result in declines in acidity in sulfuric acid-polluted lakes. Because these bacteria use organic matter as a substrate, increased organic matter loading of an acid lake should encourage bacterial sulfate reduction resulting in the loss of sulfuric acid from the water column.

To test this hypothesis, we constructed six cylindrical polyethylene enclosures in an acid (pH=3.1) lake on an abandoned coal surface mine. Tops of the enclosures were open to the air and bottoms were sunk in the mud. Organic matter in the form of anaerobic digester sludge or straw was added to two of the enclosures. Two other enclosures received additions of digester sludge or straw with $\text{Ca}(\text{OH})_2$. Two enclosures were reserved as controls. One received only $\text{Ca}(\text{OH})_2$ to control for hydrated lime additions with the organic matter. The last enclosure received no additions and served as a control for enclosure. Experiments lasted six weeks.

Alkalinity and pH increased in enclosures treated with straw. Stabilized digester sludge did not reduce acidity because it contained little readily oxidizable organic matter. In the straw treatments oxygen levels declined and sulfide was produced. More sulfide was produced where $\text{Ca}(\text{OH})_2$ and straw were added together suggesting that dissimulatory sulfate reduction is enhanced at higher pH.

Additional key words: Acid mine lakes, sulfate reduction, acid lake neutralization.

Introduction

Acid mine drainage contaminates lakes in many parts of the country but it causes especially severe problems in the midwest where both acid mine drainage and lakes are

a product of surface mining for coal (Brugam and Lusk 1986). Neutralization of acid contaminated final cut impoundments is a major problem for midwestern mining companies. Under normal circumstances inorganic bases are added to the impoundments by mining companies to reduce acidity, but a number of investigators (King et al. 1974; Campbell and Lind 1968; Turbak et al. 1979) have suggested that additions of organic matter might also enhance neutralization.

King et al. (1974) argued that the added organic matter would encourage the reduction of sulfate to sulfide within a lake removing sulfuric acid from the water column. The organic matter is a substrate for sulfate reducing bacteria of the genus Desulfovibrio (Pfennig and

¹Paper presented at the 1990 Mining and Reclamation Conference April 23-26 held in Charleston, West Virginia, USA.

²R.B. Brugam is a Professor of Biological Sciences, Southern Illinois University, Edwardsville, IL 62026. J. Gastineau is an Environmental Assessment Specialist, Illinois Geological Survey, Carbondale, IL and E. Ratcliff is a Graduate Student in the Environmental Studies Program, Southern Illinois University, Edwardsville.

Widdel 1982). These bacteria survive only under anaerobic conditions where they use the oxygen from sulfate to oxidize organic matter (a process called dissimulatory sulfate reduction). Anderson and Schiff (1985) describe the oxidation of organic matter to CO₂ by sulfate-reducing bacteria (equation 1).

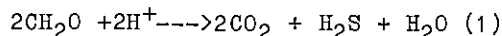

The result of this reaction is the removal of hydrogen ion from the water. King et al. (1974) suggested that the H₂S produced during dissimulatory sulfate reduction would be outgassed thereby removing hydrogen ion from the lake.

Workers with acid precipitation-influenced lakes (Schindler et al. 1980) have also suggested that sulfate reduction plays a role in the neutralization of these lakes. In contrast to the investigators of acid mine drainage, Schindler et al. (1980) have suggested that the major loss of sulfide from the lake is by precipitation as FeS.

Anderson and Schiff (1985) propose a mechanism for lake neutralization by FeS precipitation. They argue that sulfate reduction alone is inadequate to cause permanent neutralization without either precipitation of FeS or outgassing of H₂S. Although sulfate reduction produces buffer capacity in the form of H₂S (equation 1), the reduced sulfur can be quickly reoxidized to sulfuric acid under aerobic conditions (equation 2) if the H₂S gas has not escaped into the atmosphere.

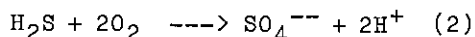

Although precipitation of sulfide with Fe⁺⁺ will prevent the reoxidation of the sulfide, it also releases H⁺ (equation 3).

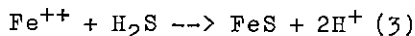

For sulfide reduction and FeS precipitation to be effective agents of neutralization, the iron in equation 3 must originate from the reduction of Fe⁺⁺⁺ (equation 4).

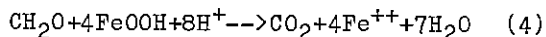

The source of the FeOOH is likely to be the lake sediment. The neutralization of a lake by precipitation of FeS must, therefore, include both the reduction of Fe⁺⁺⁺ to Fe⁺⁺ and the reduction of SO₄⁻⁻ to S⁻⁻.

King et al. (1974) originally hypothesized that organic matter addition would aid in the neutralization of acid mine drainage contaminated lakes

by providing a substrate for sulfate-reducing bacteria. We have tested this hypothesis by adding organic matter in the form of straw and sewage sludge to polyethylene enclosures in an acidic surface mine lake.

Materials and Methods

Location

Our experimental location was pit #8, a 58 ha. lake on Peabody Coal Company's Will Scarlet Mine which is located south of Crab Orchard in Saline County, Illinois (description in Jones et al. 1985). Our experimental apparatus was placed in the "middle incline", a former inclined haul road now under water. Because the acidity of the middle incline is higher than that of the open lake, it was chosen for our work. The maximum depth of the middle incline is 6m.

General Experimental Design

Experiments were performed in cylindrical polyethylene enclosures 6m long and 1 m diameter (Fig. 1). The polyethylene was held open with large plastic hoops. Six cylinders were suspended from a floating dock in the middle incline. The tops of the cylinders were open to the air and the bottoms were open and sunk in the mud of the lake bottom.

The advantage in using enclosures for limnological experiments is that small regions of a lake can be partitioned off from the main lake for experimentation. These "enclosures" allow the establishment of controls to the experimental manipulations. They also reduce the expense of experiments by reducing the amount of reagents needed. Finally, in the case of experiments where the possibility of temporary environmental degradation exists, a smaller portion of the environment is placed at risk. A disadvantage of the enclosure technique is that, although they reduce exchange of water with the open lake, they don't completely eliminate it. There is some leakage of open lake water into the enclosures.

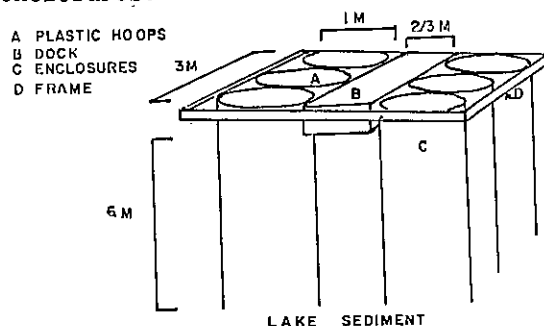

Figure 1: Experimental Apparatus

In this paper we discuss an enclosure experiment conducted at Pit #8 between August 24 and September 27, 1988. Additions to the enclosures are presented in Table 1. The control

Separate water samples were taken for general chemical analysis, for oxygen and for sulfide. Temperature and pH were measured in the field with an alcohol thermometer and a Corning portable glass electrode pH meter.

Table 1: Additions to enclosures

Treatment	Date of Addition		
	8/24/88	8/31/88	9/7/88
Control (C)	Nothing	Nothing	Nothing
Lime	3.6 kg Limestone	1.8 kg Limestone	.9kg Hydrated Lime
Straw	10 kg Straw	5 kg Straw	5 kg Straw
Sewage (Sew)	20 kg Sludge	10 kg Sludge	10 kg Sludge
Lime+Straw (LStraw)	3.6 kg Limestone + 10 kg Straw	1.8 kg Limestone + 5 kg Straw	.9kg Hydrated Lime + 5 kg Straw
Lime+Sewage (LSew)	3.6 kg Limestone + 10 kg Sludge	1.8 kg Limestone + 5 kg Sludge	.9kg Hydrated Lime + 5 kg Sludge

Laboratory Methods

In the laboratory, samples were analysed using the techniques of Standard Methods (American Public Health Association 1985). Analysis began immediately after our return from the field. Alkalinity was measured using a potentiometric titration. Acidity was measured using the hot peroxide method. Sulfate was measured turbidimetrically. Oxygen was determined using the Alsterberg modification of the Winkler technique. Sulfide was measured by iodimetric titration. Iron was measured in 1% nitric acid-preserved aliquots of the original sample by atomic absorption spectrophotometry.

Statistical Analysis

We compared treatments between enclosures using the Wilcoxon Signed Rank Test (Sokal and Rohlf 1981). For the analysis we paired measurements at each depth between treatments. Results of statistical analysis are presented as comparisons between treatments (for example, straw versus control). The Z statistic is the Wilcoxon Signed Rank Test statistic. The number of sample pairs used for comparisons was 18 (3 depths X 6 weeks).

The advantage of the Wilcoxon Signed Rank Test is its lack of assumptions about statistical distributions of the samples. An alternative test would be the paired sample ANOVA, but this assumes that the data are normally distributed and have equal variances -- assumptions that our

enclosure received no additions and was used as a test of the enclosure process. The lime enclosure allowed comparisons between organic matter additions and the inorganic bases normally employed by mining companies to neutralize lakes. Organic matter used as additives were dried straw (straw enclosure) or stabilized anaerobic digester sludge (sewage enclosure). Combinations of lime and organic matter (lime+straw and lime+sewage enclosures) were used to test the hypothesis of Schuurkes and Kok (1988) that dissimulatory sulfate reduction is limited by pH.

No special calculations of organic loading were made in advance of adding sewage sludge or straw to the enclosures. Organic matter additions were simply continued at a high level until sulfide was detected in the organically loaded enclosures.

Field Sampling

Water samples were taken from 0, 3, and 6m in each enclosure and from the open lake using a Kemmerer sampler (American Public Health Association 1985). We will discuss only the samples taken from the 3m layer in the enclosures because that depth was representative of the whole water column during the experiment. Although at other times of the year the middle incline is strongly chemically stratified below 4m, our measurements show that this stratification had broken down by the time we started our experiment.

data do not necessarily fulfill.

Results and Discussion

The sewage enclosures showed no changes that could be attributed to the organic matter additions. Apparently, the stabilized sewage sludge that we employed was dominated by recalcitrant compounds with little of the simple organic compound that form substrates for sulfate reduction.

Sulfide appeared in the lime+straw and straw enclosures by the second week (Fig. 2). The amounts of sulfide in the lime+straw enclosure were always higher than those in the straw enclosure (lime+straw versus straw, $Z=-2.61$, $P=.0092$). As sulfide increased in the lime+straw and straw enclosures dissolved oxygen decreased until it disappeared. Likewise, pH (Fig. 3) and alkalinity (Fig. 4) increased in the enclosures containing straw. As expected pH and alkalinity also increased in the lime enclosures.

Acidity declined in all enclosures throughout the experiment (Fig. 5). It is unclear why acidities were so high at the beginning of the experiment. The usual acidity of surface water of the lake was approximately 50 mg/l CaCO_3 -- the level to which the control enclosure declined by week 3. The acidity of the straw treatment declined even more than the controls (straw versus control, $Z=-3.10$, $P=.0019$). Acidity declined most in enclosures which received lime additions (lime+straw versus control, $Z=-3.52$, $P=.0004$; lime versus control, $Z=-2.95$, $P=.0032$). Acidity in the straw enclosure only briefly declined to zero even though alkalinity and pH rose. Otherwise, significant acidity remained in the straw enclosure. The acidity in the straw enclosure was less than in the control enclosure, however (straw vs. control $Z=-3.10$, $P=.002$).

The straw treatment increased Fe concentrations (straw vs. control $Z=-2.44$, $P=.02$, Fig 6). When inorganic neutralizing agents were added with the straw, iron remained unchanged (lime+straw vs. control $Z=-.46$, $P=.65$).

Sulfate concentrations remained unchanged in all enclosures during the course of the experiment. The conversion of sulfate to sulfide in the straw enclosures seems not to have had any effect on sulfate concentrations (Fig. 7). The sulfate equivalent to the sulfide we found is small (25 mg/l S^{--} = 75mg/l SO_4^{--}) in relation to the usual concentration of sulfate present in the lake (2,000 mg/l). This means that approximately 4% of the sulfate was converted to sulfide -- a change unlikely to be detected using the turbidimetric method of sulfate

analysis.

We have found that organic additions do neutralize acidic lakes by supporting the production of sulfide. Our experiment shows a rise in pH to approximately the pK_a of hydrogen sulfide (6.95).

Because combined additions of CaCO_3 , $\text{Ca}(\text{OH})_2$ and straw produced larger amounts of sulfide than straw alone, dissimulatory sulfate reduction seems to be limited by pH as Schuurkes and Kok (1988) suggest. The inorganic neutralizing agents raise pH to optimal levels for sulfate reduction supported by the added organic material. Straw alone also allows sulfate reduction, but rates of reduction are inhibited by the lower starting pH. The accumulating H_2S eventually raises pH sufficiently to allow accelerated sulfide production.

A major problem with our organic matter additions is that neutralization was not permanent. High pH and alkalinity existed only as long as sulfide existed. As soon as the sulfide was reoxidized, pH dropped and alkalinity disappeared. Our measurements of iron show that there was no significant precipitation of FeS from the water column. Water drawn from the enclosures was grey in color turning black with FeS only on standing in sampling bottles. This phenomenon has also been seen by Stahl (1978). It suggests that FeS precipitation is prevented in situ.

It is unclear what prevents the precipitation of FeS in the enclosures. The concentrations of iron and sulfide in the straw enclosure on week 3 are high (total Fe= 76 mmolar, total sulfide = 313 mmolar). The pH at the same time is 5.5. It would seem that these conditions would be conducive to strong FeS precipitation.

One possible mechanism preventing metal sulfide precipitation could be chelation by organic compounds. In naturally acidic lakes organic material from decaying plants are strong iron chelators (Hutchinson 1957). The decay of straw probably also produces chelators which make Fe unavailable for FeS precipitation.

The practical result of metal chelation is the prevention of the loss of mineral acidity that we might expect from metal sulfide precipitation. This result limits the usefulness of direct application of organic matter to acid lakes. Organic addition might be more successful if it were done in the hypolimnion (deep water) of a lake. These waters are sealed off from the atmosphere and are anaerobic for a longer time period than is possible in

SULFIDE

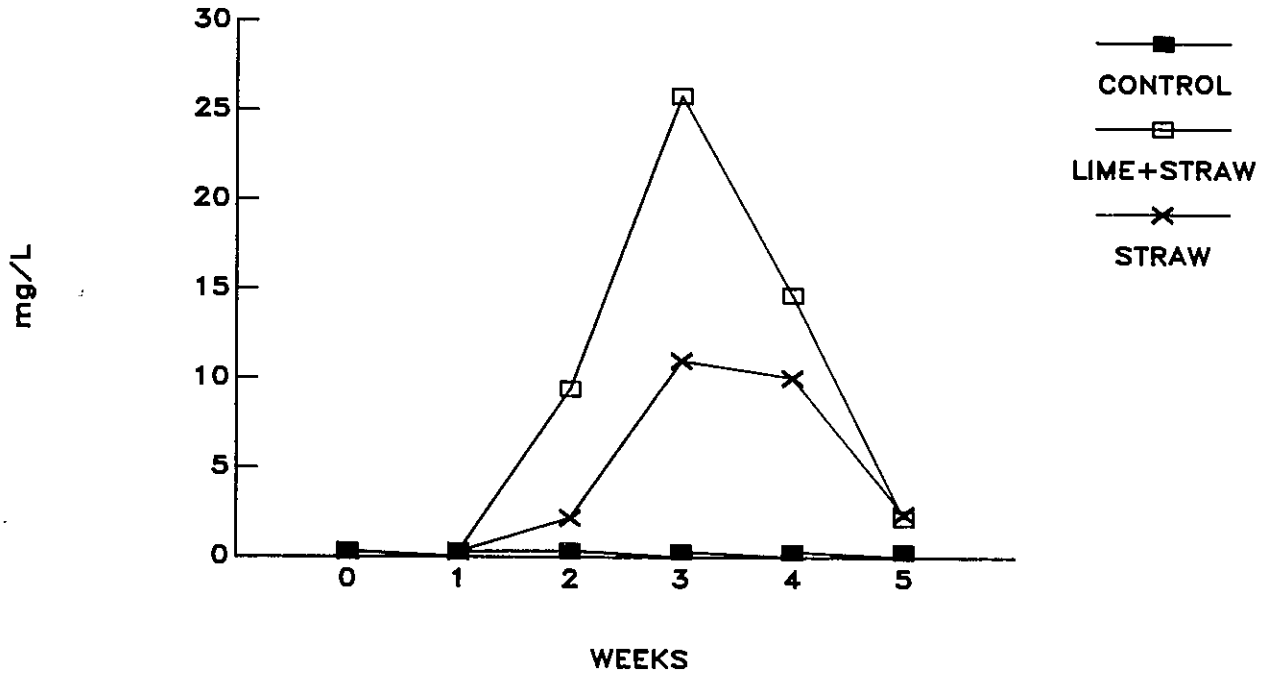

Figure 2.: Sulfide concentrations at the 3 m level in the experimental enclosures

pH

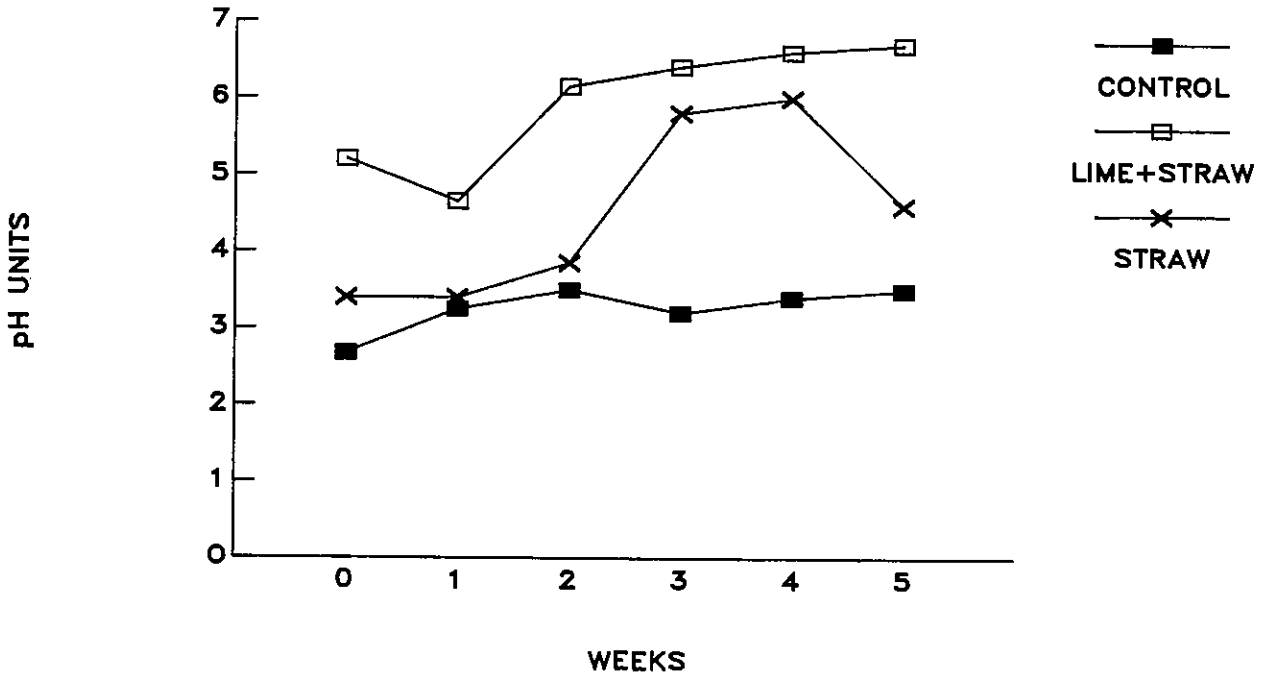

Figure 3: pH at the 3 m level in the experimental enclosures.

ALKALINITY

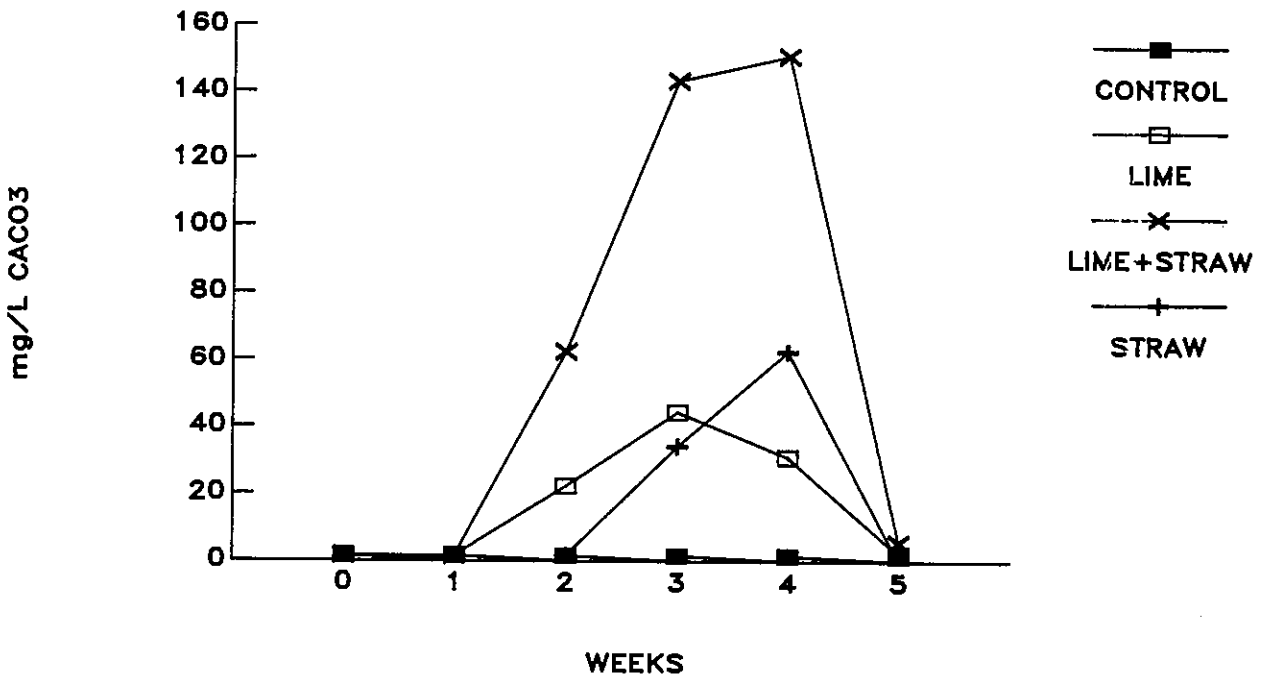

Figure 4: Alkalinity at the 3 m level in the experimental enclosures

ACIDITY

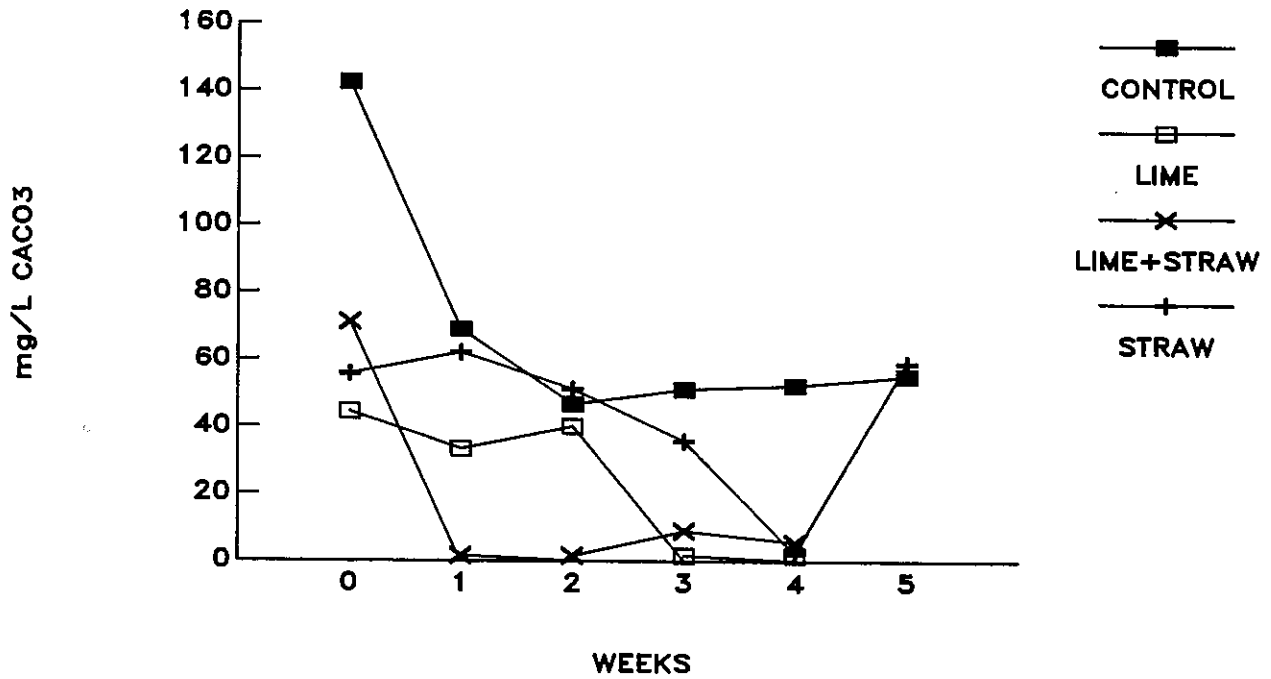

Figure 5: Acidity at the 3 m level in the experimental enclosures.

IRON

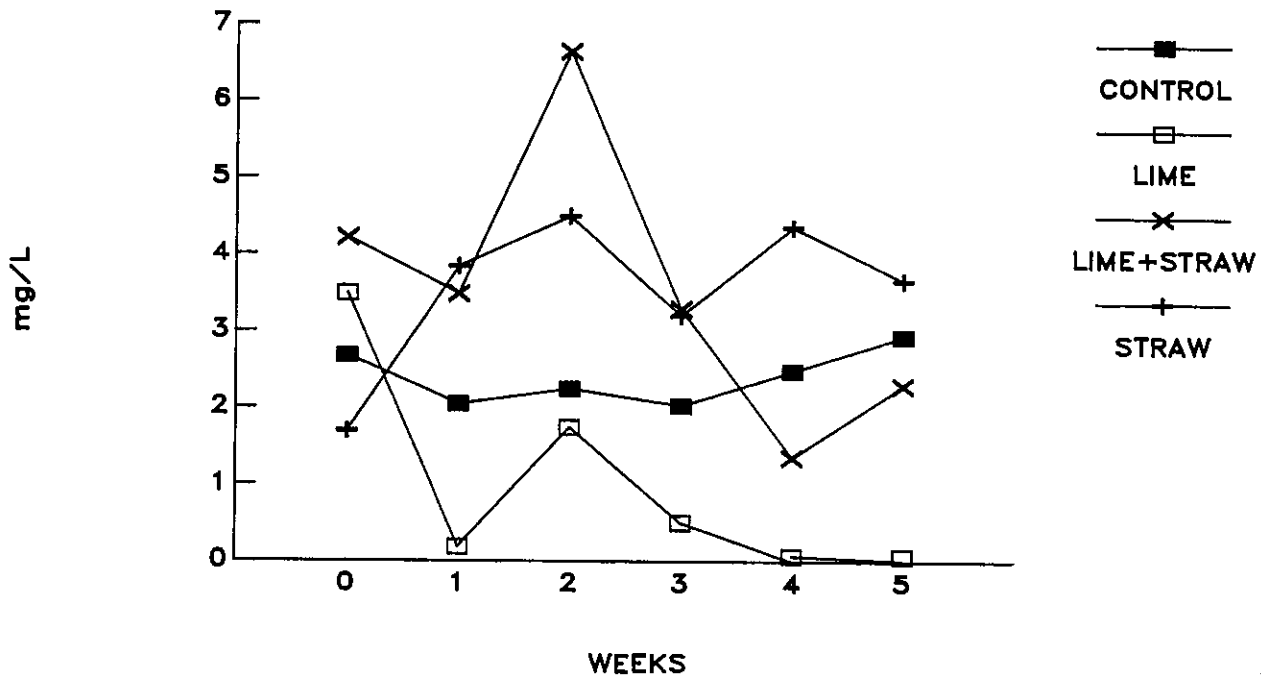

Figure 6: Iron concentrations at the 3 m level in the experimental enclosures.

SULFATE

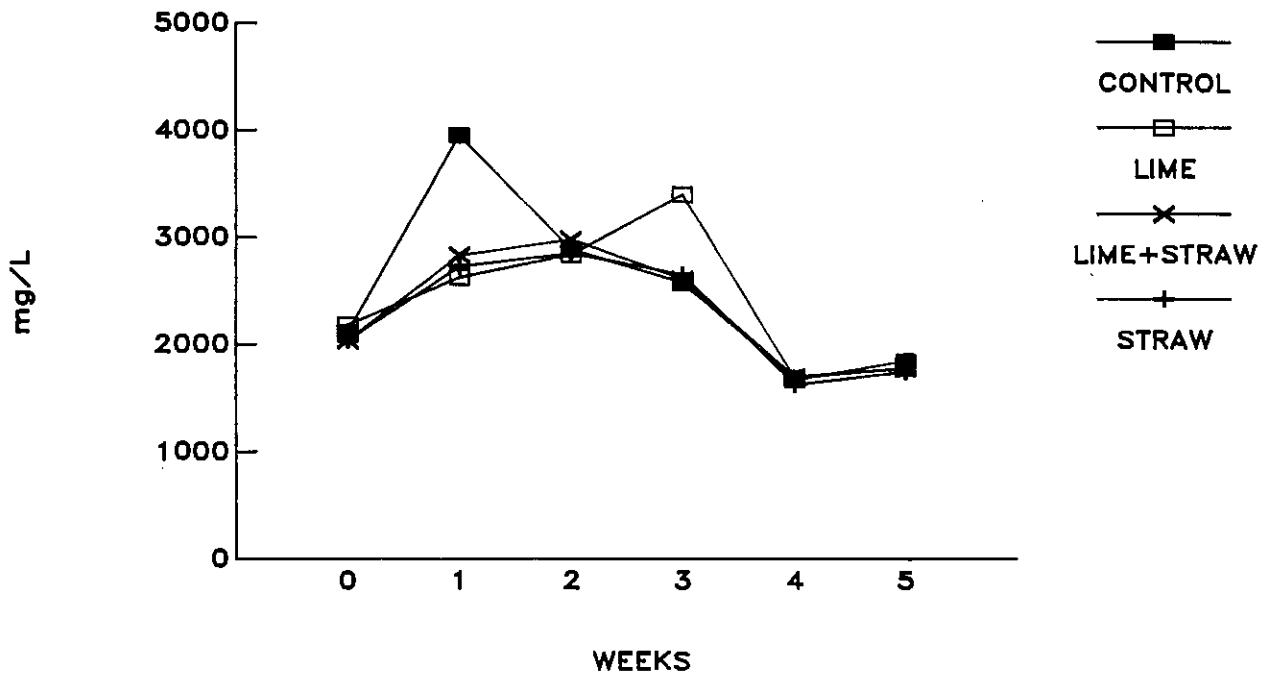

Figure 7: Sulfate concentrations at the 3 m level in the experimental enclosures.

our enclosures. The longer time available for decay might allow more complete decomposition of potential chelating substances generated from the straw.

If the organic matter is added to the hypolimnion of a lake one might expect that H₂S would be brought into the epilimnion and oxidized at turnover. For the process to be successful, sufficient FeS must be entombed in the sediment to prevent the reoxidation of sulfide. Herlihy et al. (1987) found that the deep water sediment of an acid mine drainage-influenced lake was a location of strong sulfate reduction which permanently removed acidity and sulfate from the overlying water. It is unclear why there should be a permanent loss of acidity in the lake Herlihy et al (1987) studied but not in Pit 8.

Our results suggest that additions of mineral bases along with the organic matter might also increase metal sulfide precipitation by increasing pH enough to make such precipitation more probable. Davison (1986) used a combination of organic matter with hydrated lime to neutralize an acidic sand quarry in England. He found that neutralization occurred but provided no test of whether the combination of materials was more effective than the hydrated lime alone. Our results suggest that this might be true.

Conclusions

Additions of organic matter to acid lakes to encourage dissimulatory sulfate reduction does neutralize these lakes. At present, however, it is unclear whether neutralization is permanent.

Acknowledgements

This work was supported by the U.S. Bureau of Mines contract No. JO178025. We thank Patricia Erickson and Pamela MacIntire from the Bureau of Mines for thoughtful discussions about this project. I am especially grateful to the Illinois Division of Peabody Coal Company for allowing me access to the Pit #8 site and to Robert Hill and Phil Stafford of Peabody Coal for help and guidance at the mine.

Literature Cited

American Public Health Association. 1985. Standard Methods for the Examination of Water and Wastewater. 874 p.

Anderson, R.L. and S.L. Schiff. 1987. Alkalinity generation and the fate of sulfur in lakes sediments. *Can. J. Fish. Aquat. Sci.* 44(Suppl. 1): 188-193

<http://dx.doi.org/10.1139/f87-294>

Baas-Becking, L.G.M., I.R. Kaplan, and D. Moore. 1960. Limits of the natural environment in terms of pH and oxidation-reduction potentials. *Journal of Geology* 68:243-283 <http://dx.doi.org/10.1086/626659>

Brugam, R.B. and M. Lusk. 1986. Chapter 10: Diatom evidence for neutralization in acid surface mine lakes. In *Diatoms and Lake Acidity* J. Smol, R.W. Battarbee, R.B. Davis, J. Merilainen eds. Dr. W. Junk, Dordrecht p. 115-129.

Campbell, R.S., and O.T. Lind 1969. Water quality and aging of strip-mine lakes. *J. Wat. Pollut. Cont. Fed.* 41:1943-1955.

Davison, W. 1986. Sewage sludge as an acidity filter for groundwater-fed lakes. *Nature* 322:820-822 <http://dx.doi.org/10.1038/322820a0>

Jones, D.W., M.J. McElligott, and R.H. Mannz. 1985. Biological, Chemical and Morphological Characterization of 33 Surface Mine Lakes in Illinois and Missouri. Peabody Coal Co. 248 p.

Herlihy, A.T., A.L. Mills, G.M. Hornberger, and A.E. Bruckner. 1987. The importance of sediment sulfate reduction to the sulfate budget of an impoundments receiving acid mine drainage. *Water Resources Research* 23:287-292.

<http://dx.doi.org/10.1029/WR023i002p00287>

Hutchinson, G.E. 1957. *Treatise on Limnology. Vol I. Geography, Physics and Chemistry.* Wiley Interscience, New York. 1000 p.

King, D.L., J.T. Simmler, C.S. Decker, and C.W. Ogg. 1974. Acid strip mine lake recovery. *Journal of the Water Pollution Control Federation* 42:2301-2316.

Pfennig, N. and F. Widdel. 1982. The bacteria of the sulphur cycle. *Phil. Trans. R. Soc. B* 433-441.

Schindler, D.W. and R. Wagemann, R.B. Cook, T. Ruscynski, and J. Prokopowich. 1980. Experimental acidification of Lake 223, Experimental Lakes Area: Background data and the first three years of acidification. *Can. J. Fish. and Aquat. Sci.* 37:342-354.

<http://dx.doi.org/10.1139/f80-048>

Schuurkes, J.A.A.R., and C.J. Kok. 1988. *In vitro* studies on sulphate reduction and acidification in sediments of shallow soft water lakes.

<http://dx.doi.org/10.1111/j.1365-2427.1988.tb00361.x>

Freshwater Biology 19:417-426.

Sokal, R.B. and F.J. Rohlf. 1981.
Biometry: Principles and
Practice of Statistics in
Biological Research. W.H.
Freeman & Co. San Francisco.875p.

Stahl, J.B. 1978. Water and peculiar
stratification in an
organically loaded strip-mine
lakes. Water Research 13: 467-
471.

[http://dx.doi.org/10.1016/0043-1354\(79\)90040-X](http://dx.doi.org/10.1016/0043-1354(79)90040-X)

Turbak, S.C., G.J. Olson, and G.A.
McFeters. 1979. Impact of
western coal mining. I. Chemical
investigations of a surface
coal mine sedimentation pond.
Water Research 13: 1013-1031.

[http://dx.doi.org/10.1016/0043-1354\(79\)90067-8](http://dx.doi.org/10.1016/0043-1354(79)90067-8)

